

DALLARA F300

FORMULA 3/2000
USER MANUAL

CONTENTS

CAR INFO		4-5
SET-UP		6-7
SUSPENSION	FRONT	8-12
	REAR	12-14
RIDE HEIGHT		15
DIFFERENTIAL		16-17
DAMPERS		18-19
AERODYNAMICS		20-24
UPRIGHT & HUB ASSEMBLY		25-26
SYSTEMS	OIL	27
	BRAKES	28
	FUEL	29
	ELECTRICS	30-33
	EXTINGUISHER	34
GEARBOX		35
SAFETY AND UTILITY NOTES		36-37
TIGHTENING TORQUES		38
CONVERSION TABLE		39
GENERAL AGREEMENT AND WARRANTY		40
CERTIFICATES (& FIA DOCUMENTS)		41-

GENERAL DIMENSIONS AND SUPPLIERS

Wheelbase	2678mm
Front Track	1500mm
Rear Track	1430mm
Overall height	915 mm (from ground to top of roll hop)
Overall width	1750 mm (wide front suspension)
Overall length	4060 mm (front endplate to rearmost edge of rear wing)
Weight	540 Kg (including driver and ballast)
Front suspension	push-rod monodamper
Rear suspension	push-rod twin damper
Chassis	Carbon and KEVLAR™ sandwich with AL / NOMEX™ h/comb
Bodywork	Glass fibre prepreg with NOMEX honeycomb
Composites	HEXCEL-HERCULES
Castings	AGUSTA/FLABO
Gearbox	DALLARA casing, five ratios and reverse gear
Gears and differential	HEWLAND
Springs	EIBACH 36 mm ID
Dampers	KONI 2812-140 (bump and rebound adjustable)
Fuel cell	PREMIER – FT3
Extinguisher system	SPA design (electrical operated)
Steering wheel	OMP – 270 mm OD
Steering release system	SPA design
Coolers	BEHR
Filters	FIAAM
Rims	SPEEDLINE 9" front – 10.5" rear
Brake system	BREMBO
Battery	FIAMM
Seat belt	TRW-SABELT
Installed engines	Fiat, Alfa, BMW Novamotor Honda Mugen Opel Spiess Renault Sodemo Toyota Tom's Mitsubishi HKS VW Bertil's (USA).

SET-UP**TIRE INFORMATION**

Tire dimensions depend on tyre pressure, rim width and camber angle.

The stiffness values are based on the recommended inflating pressure (hot tyres).

FRONT TIRE	Avon	Bridgestone	Michelin	Pirelli	Yokohama
Specification	180/550-13	180/550-13	20/54-13	200/530-13	180/50-13
Free radius (mm)	277.5	277.2	272.3	266.3	278.0
Loaded radius (mm)	272	271.5	267.8	261.5	273.2
Vertical stiffness (Kg/mm)	21.0	14.4	20.7	17.1	17.0
Hot tire pressure (bar)	1.5	1.5	1.55	1.5	1.6
REAR TIRE					
Specification	250/570-13	240/570-13	24/57-13	250/575-13	240/45-13
Free radius (mm)	287.0	286.5	289.1	289.4	288.0
Loaded radius (mm)	281.3	279.0	284.0	282.0	281.0
Vertical stiffness (Kg/mm)	22.8	16.7	21.8	17.2	17.8
Hot tire pressure (bar)	1.65	1.5	1.6	1.55	1.55

SUGGESTED SETUP

The set-ups consider the complete car with the driver seated, ready to race.

The front anti roll setting pre-load is 'double stiffness' pre-load, for details look at the FARB pages.

FRONT	Avon	Bridge	Michelin	Pirelli	Yokohama
Ride height (mm)	15	15	15	15	15
Camber (deg)	2°45'	3°15'	3°45'	4°	3°15'
Toe (deg) (total two wheels)	20' OUT	10' OUT	20' OUT	20' OUT	20' OUT
Springs (lb/in)	800	700	800	800	700
Vertical Pre-load (mm)	8	6	8	5	5
Solid spacer (mm)	6	6	6	6	6
Push rod length (mm)	682.5	682.5	689.5	689.5	682.5
Roll centre setting	STD	STD	STD	STD	STD
Roll bar setting	<<>><<	<<>><<	<<>><<	<<>><<	<<>><<>>
Roll pre-load (notches)	9	9	9	9	0
REAR					
Ride height (mm)	34	34	34	34	34
Camber (deg)	2°00'	2°15'	3°30'	3°15'	2°45'
Toe (deg) (total two wheels)	10' IN	20' IN	0	0	10' IN
Springs (lb/in)	900	800	900	900	800
Pre-load (mm)	0	0	0	0	0
Push rod length (mm)	572	572	572	572	572
Roll centre setting	STD	STD	STD	STD	STD
Roll bar	21 OD	24 OD	24 OD	24 OD	24 OD
Differential setting	60/80#4	60/80#6	60/80#4	60/80#6	60/80#4

SETUP ADJUSTMENT**EFFECTS ON ADJUSTMENTS ON THE SET-UP**

Positive change in:	means:
Height	car rises
Toe	toe-out
Camber	upper part of rim outward
Castor	lower part of rim points ahead

ADJUSTMENTS

		FRONT	REAR
PUSHROD ADJUSTER			
+1TURN	Height change Camber change (deg) Thread step	4.30mm 2' M1.25R+24/"L=2.31mm	6.52mm 14' M1.25R+24/"L=2.31mm
TOE ADJUSTER (PER WHEEL)			
+1TURN	toe change (deg) thread step	36' 24/"	1°25' M1.25R+24/"L=2.31mm
CAMBER SPACER	+1mm toe variation	17'	15' 0.5mm = 18'
CASTOR ADJUSTER			
+1TURN	Castor change (deg) thread step height change (mm) camber change (deg) toe change (deg)	26' 24/" -0.8 -7' 2'	20° brakecaliper=14.5° -38' 20/" -0.2 4' -4'
SPRING PLATFORM			
+1TURN	thread step (mm) height change (mm)	2 1.78	2 2.42
WHEEL/SPRING RATIO (vertical)		0.91	1.21
WHEEL/BELLEVILLE RATIO (lateral)		1.56	--
WHEEL/DROP LINK RATIO (roll)		--	1.77
ROLL CENTRE HEIGHT		Tyre dependent	Tyre dependent

Available front camber spacers: 1.0, 1.5 and 2.0 mm. For the rear are available 0.8, 1.0, 1.2, 1.5 and 2.0mm. Combine these to make fine adjustments.

Front and rear wheel to spring, front wheel to Belleville and rear wheel to drop link motion ratios may be considered as constant for all the wheel motion.

FRONT SUSPENSION

VERTICAL or SPRING PRELOAD

In a non pre-load condition, as long as the damper is not fully extended, turning the platform C raises the ride height and lowers slightly the pressure inside the damper.

When the damper gets fully extended, turning-on the platform C puts vertical spring pre-load on the car. We advise though, not to proceed this way, because some dampers (including Koni) should not be used fully extended. Therefore we advise to use the droop-stop 'A'.

Remind that there is some pre-load in each damper. With a Koni damper this pre-load is about 30kg.

This pre-load depends on damper type, settings and internal gas pressure.

Pre-load is the force that has to be applied on the spring to start to modify its length with respect to the static value. To set the on car pre-load, put the car with the driver seated on the set-up floor. Unscrew the droop-stop A to contact the opposite bolt B. Now turn platform C to set the pre-load. As the platform thread step is 2 mm, the pre-load $P = K_s \times t \times 2$

P = pre-load in kg

K_s = spring stiffness in kg/mm (spring stiffness in Lb/in) / 56 = spring stiffness in kg/mm

T = number of platform C turns

2 = mm / turn (for Koni)

SETTING THE 'ON CAR PRE-LOAD'

Mount the damper-spring combination with the platform C just in contact with the spring.

Mount damper-spring combination on the car and put the car with the driver seated on the set-up floor. Make the car bounce a few times to settle down.

Screw the droop-stop A into the rocker, away from touching bolt B.

Adjust ride height with the pushrod adjusters to the desired setting.

Bring droop-stop A in contact with bolt B.

Turn platform C until desired pre-load force is achieved. ($P = K_s \times t \times 2$)

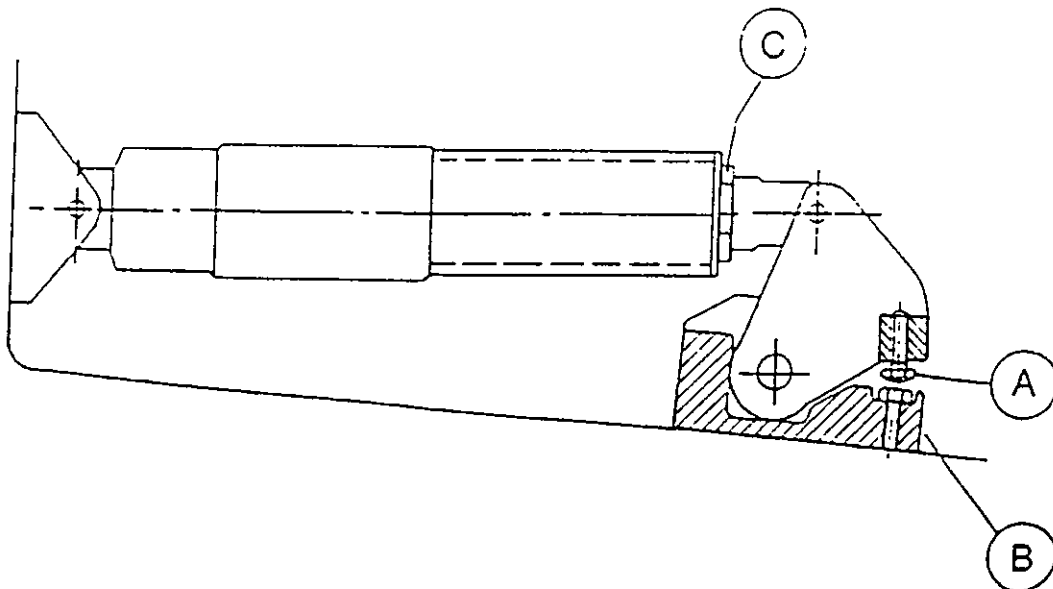

FRONT ANTI ROLL AND PRE-LOAD

There are 3 different ways of setting the front anti-roll Belleville washers.

- 1) Mount a stack configuration and turn the platforms just in contact with the stack. This way there is **no pre-load** on the stack and the roll stiffness is the nominal stack stiffness.
For example: the configuration <<<>>> gives 761kg/mm stiffness.
- 2) When both platforms get turned on a few notches the system is preloaded. The roll stiffness under this **pre-load is double the nominal stiffness**. When the rocker passes the pre-load the stiffness gets back to the nominal.
For example: >><<>> + 5 notches is for 0.5mm of lateral movement $761 \times 2 = 1522 \text{kg/mm}$ stiff.
- 3) When both platforms get turned on a few notches and locked up with the two extra locknuts the system is **infinite stiff**, this means there is no lateral movement as long as the force doesn't overcome the pre-load. Once the pre-load passed, the stiffness gets back to nominal.
 - Both pre-load settings (2 and 3) generally help for sharper turn-in.
 - Soft no pre-load settings (1) can make the tyres last longer and make the car easier to drive.
 - Over the pre-load, the stiffness gets back to the nominal stiffness. The driver may prefer some pre-load in certain conditions (turn-in...) and wish to overcome the pre-load in some other conditions (mid corner, curbs...). Set accurately the transition point of 'pre-load / no pre-load' since the consequently stiffness variation is sudden and reflects immediately on the cars' balance and behaviour.
 - You can combine different stacks in series to obtain a progressive load / displacement characteristic. Total length of the combined stack should never be more than 28mm.

Pay attention to:

-The clearance between the platform and the rocker (B) should not be more than 6.5mm when platform just touches the Belleville stack, with no pre-load.

-For any Belleville stack, in running condition, rocker lateral displacement and the chosen pre-load must never reach the "Maximum Deflection" (see Table below), to avoid a sudden lateral locking of the rocker.

BELLEVILLE STACK CONFIGURATIONS (Belleville thickness 2.0mm)

Stack configuration	Nominal stiffness kg/mm	Stack length mm	Maximum deflection mm		Maximum notches
<<<<>>>>	2504	17.50	1.12	→ respect maximum notches when using pre-load configurations →	8
<<<>>>	1796	13.50	1.12		8
<<<>>><<<	1197	20.25	1.69		12
<<>><<	761	14.25	1.69		12
<<>><>>	571	19.00	2.25		17
<<>><>><<	457	23.75	2.81		22
<><	362	8.25	1.69		14
<><>	272	11.00	2.25		17
<><><	218	13.75	2.81		22
<><><>	181	16.50	3.37		26
<><><><	155	19.25	3.93		28

SETTING THE PRE-LOAD

DOUBLE STIFFNESS PRE-LOAD

- Mount the stack you want to use and turn the platform until contact with the Belleville stack
- Adjust by turning the platforms until distance A is the same on both sides
- Check distance B to be less than 6.5mm, if more, replace adjustment spacer
- Mark this platform position as the "zero pre-load" notch
- Turn both left and right platforms the amount of notches to set the desired pre-load. One turn of platform is 15 notches corresponding to 1.5mm displacement (1 notch = 0.1mm)

INFINITE STIFFNESS PRE-LOAD

- Set the pre-load as described for the double stiffness procedure here above
- Mount nut D in contact with the platform
- Tighten counter nut E against nut D

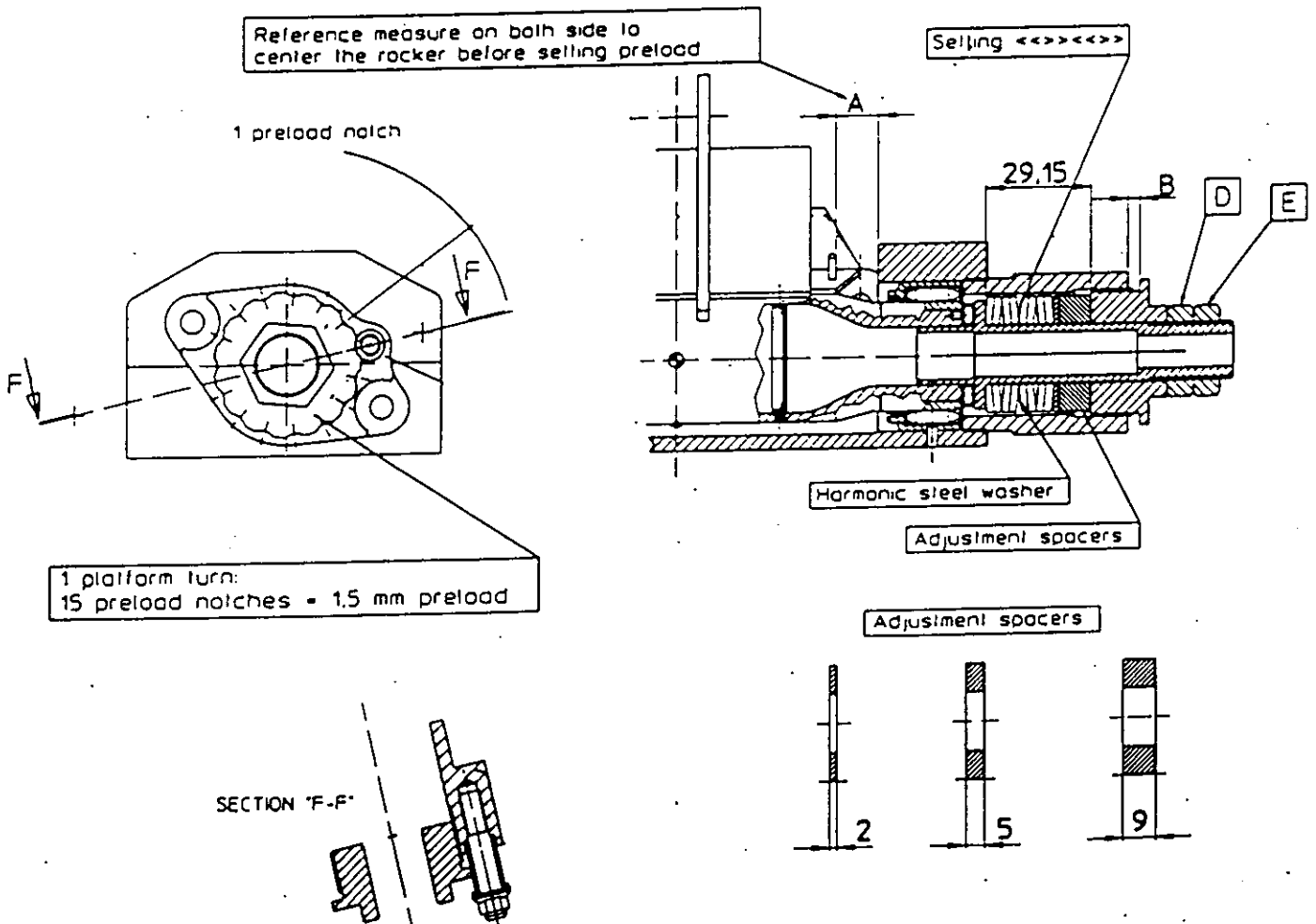

FRONT ROLL CENTER

Moving the spacer underneath or above the lower wishbone spherical joint changes the height of the front roll centre. When choosing "low roll centre" configuration, push-rod length has to be shortened by 1.4 register turns (8 faces of the adjuster) to keep the car at the same ride height.

When adjusting the roll centre height, there will also be a slight change in camber gain in function of vertical wheel travel.

OPTION	Roll centre height static ride height	Camber change for 10mm wheel travel
Std	X	5'
Low	-12.5 mm	3'

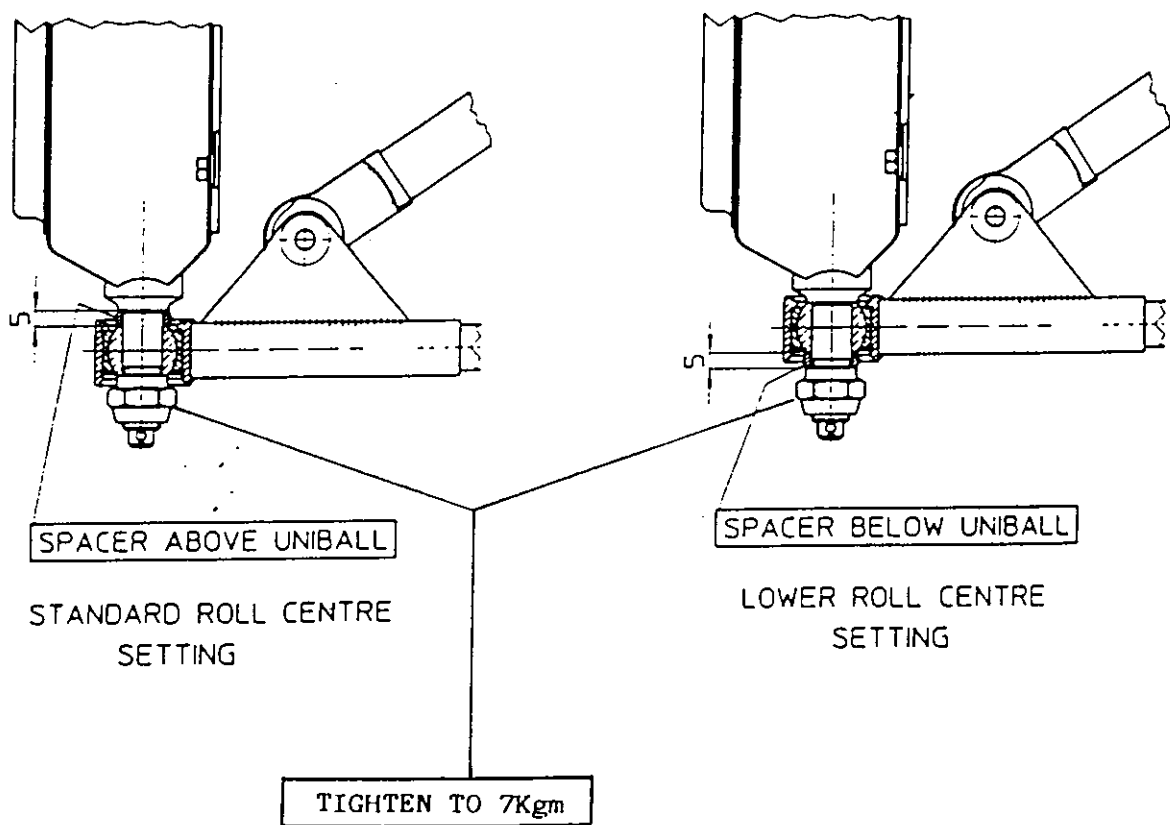

STEERING ASSEMBLY

Pinion primitive diameter	15.71 mm
Static steering ratio	12.6 steering wheel/wheel
Ackermann [%]	28.5

MEASURING CASTOR

FRONT

When the car is flat (front ride height equals rear) and the front upright inclination is 1.80° , castor angle is 10.5° .

With different front to rear ride heights, castor angle changes because of the pitch angle of the car. For instance, with 15 mm front and 40mm rear ride height, measured at wheel axis, (wheelbase is 2678 mm) the pitch angle is 0.53° as:

$$\text{Pitch angle } (40-15)/2678 = 1 / \tan 0.53^\circ \quad \text{castor angle: } 10.5^\circ - 0.53^\circ = 9.97^\circ$$

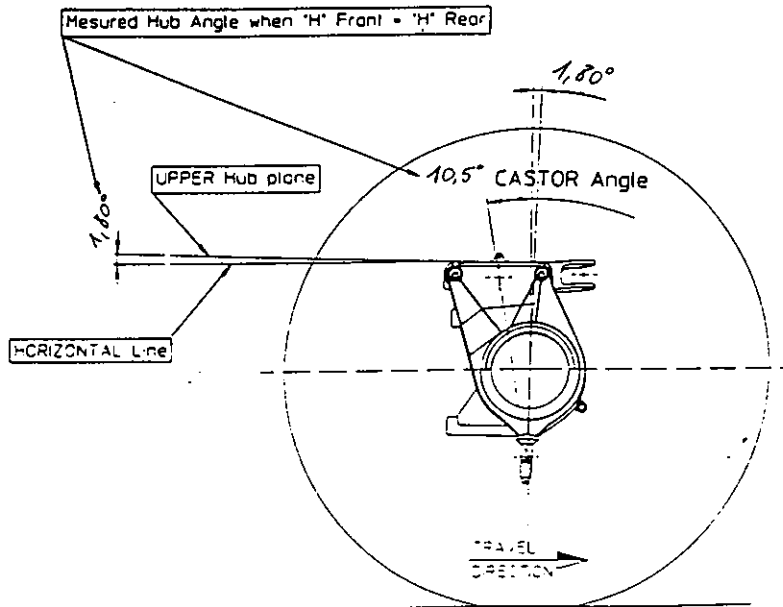

REAR

The rear wheel castor (not relevant because the wheel is not steered) can be checked using the brake-calliper mounting platforms.

When the car is flat (front ride height equals rear) and the measured angle is 20° the castor is 14.5° . The pitch angle must be added because the castor is rearward.

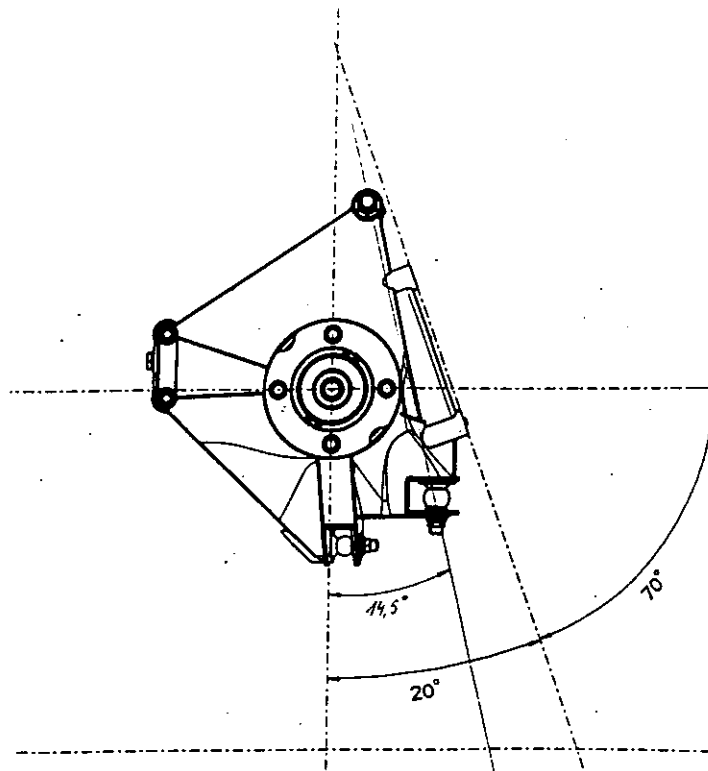

REAR SUSPENSION

REAR SUSPENSION ROLL CENTER AND ANTISQUAT SETTING

OPTION	Roll centre height static ride height	Camber change for 10mm wheel travel	Antisquat %
A-1	std	21'	48
B-2*	-15	17'	48
C-1	+15	25'	48
D-1*	std	21'	60
E-2*	-15	17'	60
F-1	+5	22'	30
G-2	-10	18'	30

Option D-1 and E-2 alter caster angle. To obtain std value **shorten by 2 turns** the 'castor' uniball.
 Option B-2 needs special bracket for front top mounting (available at Dallara)

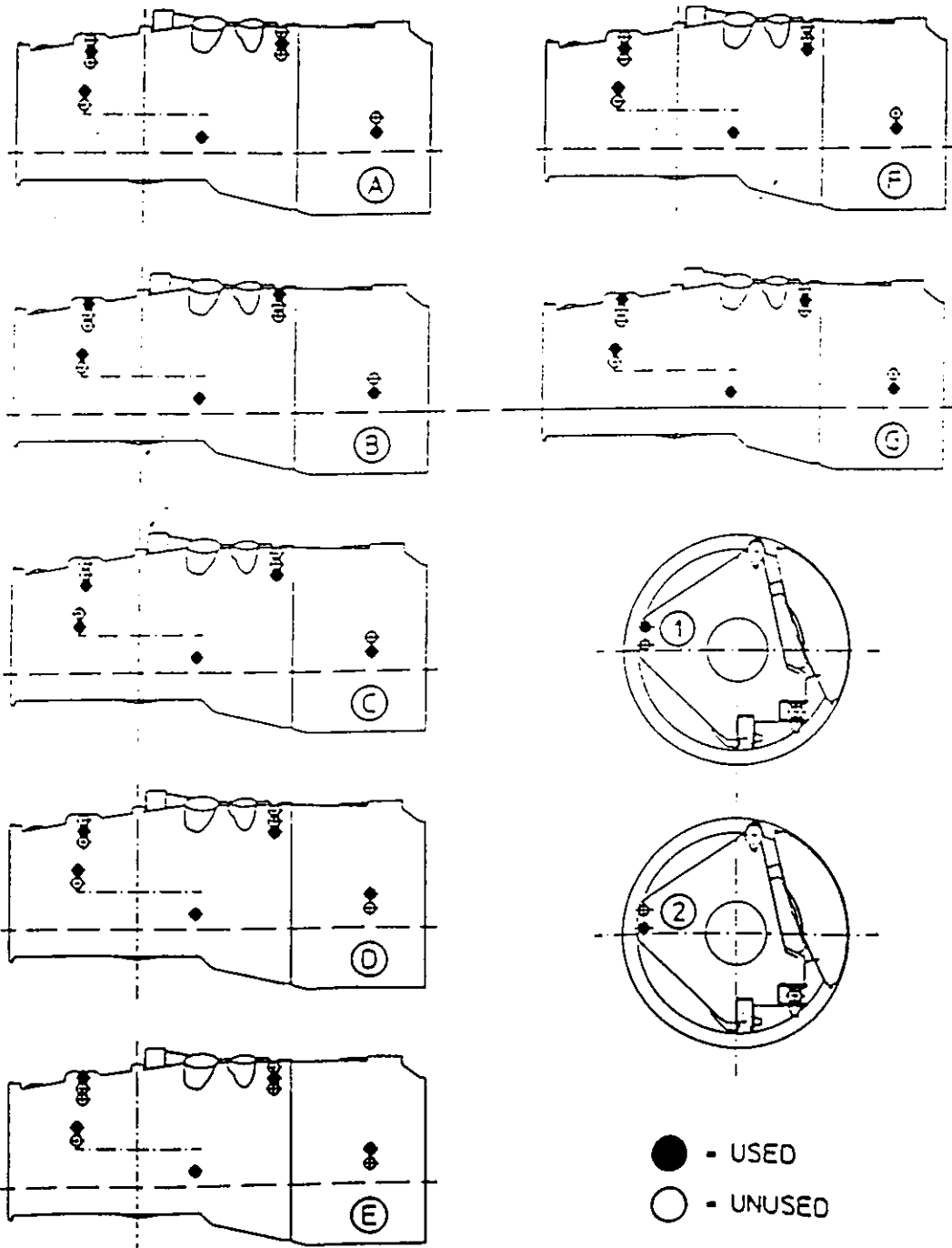

REAR ANTIROLL BAR STIFFNESS

F300 has a rear antiroll bar with two 75mm long adjustable blades.

40mm diameter ARB is the stiffest available, this can be milt down to any softer ARB.

The two digits in this table represent the blade positions: 1=full soft, 5=full hard. Stiffness in kg/mm.

OD	1-1	1-5	2-5	3-5	4-5	5-5
14 mm	22.6	24.8	25.1	25.9	27.0	27.6
16 mm	33.4	38.6	39.2	41.2	44.0	45.5
19 mm	50.6	63.3	65.1	70.9	79.5	84.6
21 mm	61.1	80.7	83.6	93.4	108.9	118.6
24 mm STD	73.8	104.3	109.2	126.7	156.8	177.9
28 mm	85.1	128.6	136.1	164.3	218.9	262.2

REAR SUSPENSION ROCKER REPLACEMENT

The rear rocker spins around a steel pivot 'A' fitted onto the gearbox casing by stud B, fixed with LOCTITE 242™. The following procedure shows the disassembly of the rocker and the pivot A. Contact DALLARA customers' service to get the tools E and F.

- Unscrew nut C. The tightening torque to fit it back is 3.5 Kgm;
- Take off the top cap and the rocker;
- Unscrew nut D with a long 14mm tubular dowel. The tightening torque to fit it back is 5.5 Kgm;
- Fit extractor F around the pivot's outer flange, screwing in bolt E, and remove the pivot
- Remove stud B with the proper tool. The stud is fitted with Loctite in its insert. When removing the stud, heat up the stud's thread to break the Loctite with a heatgun up to 140 C°.

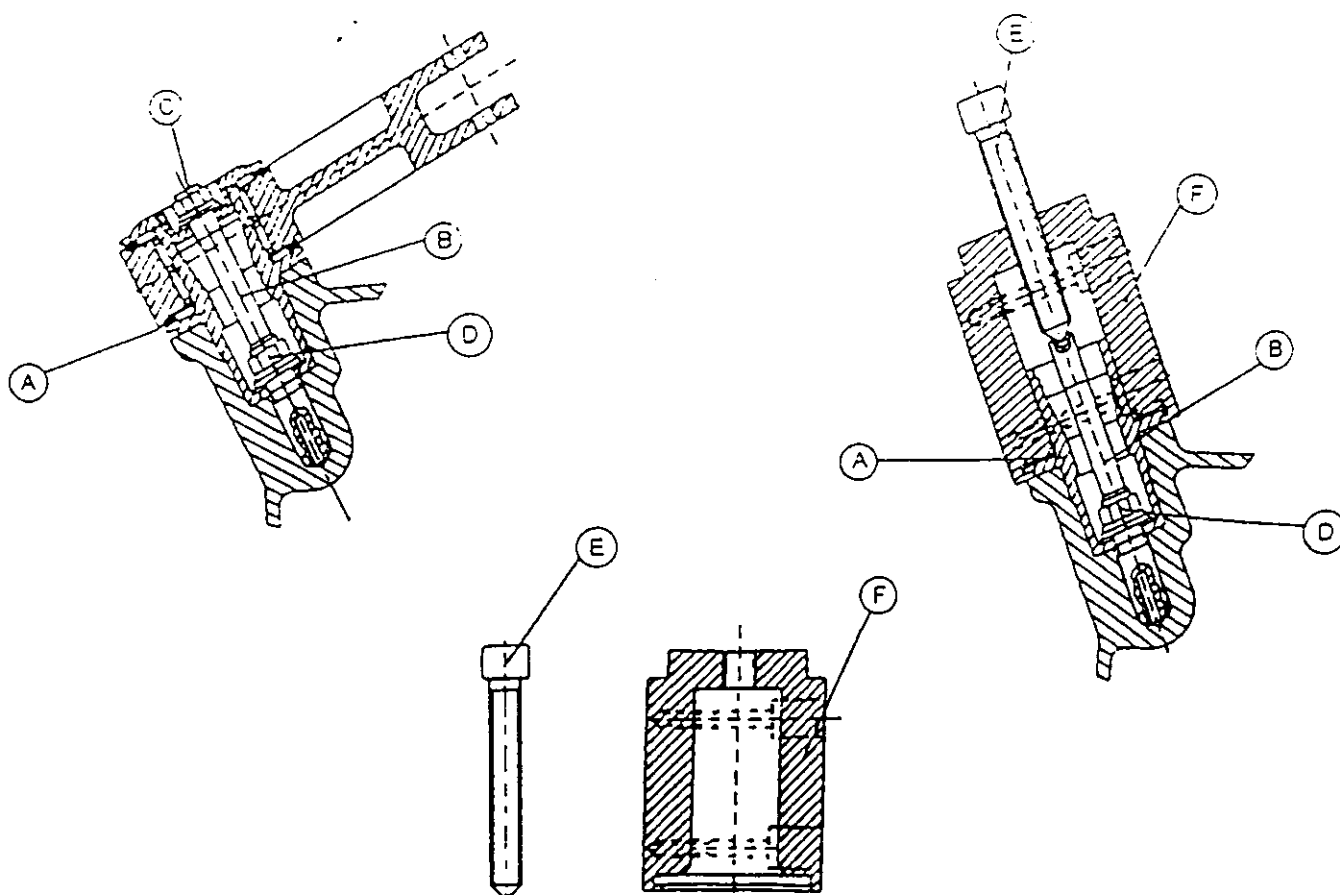

RIDE HEIGHT CHECK AND REFERENCES

Ride height is fundamental for setting and changing the aerodynamic performance of the car. It might be difficult to measure it directly, so we provide alternative references.

The example shows **front ride height 15mm** and **rear 34mm** (at wheel axis). With 2678mm wheelbase, pitch angle is 0.40° . Calculation: $(34 - 15) / 2678 = \text{inv. tan } x \rightarrow x = 0.40^\circ$
(The two round platforms on top of the tub to measure front ride height at front axis are 50mm behind the axis when using the long wheelbase front suspension)

Measuring front ride height:

A flat surface (skid) about 310 mm behind the wheel axis and 50 mm behind the skid leading edge. You can measure its distance from ground as $17 - (\tan 0.40^\circ \times 310) = 15\text{mm}$

Measuring rear ride height:

Two machined areas, at 327.5 mm from car bottom, on the gearbox at wheel axle line. You can measure their distance from the ground as $361.5 - 327.5 = 34\text{mm}$ height.

Under the flat bottom, 50mm ahead of the start of the diffuser and 313mm ahead of the rear wheel axis, you can measure and calculate the floor distance from the ground as following: measured 32mm + $(\tan 0.40^\circ \times 313) = 34\text{mm}$

REAR RIDE HEIGHT

34mm

FRONT RIDE HEIGHT

15mm

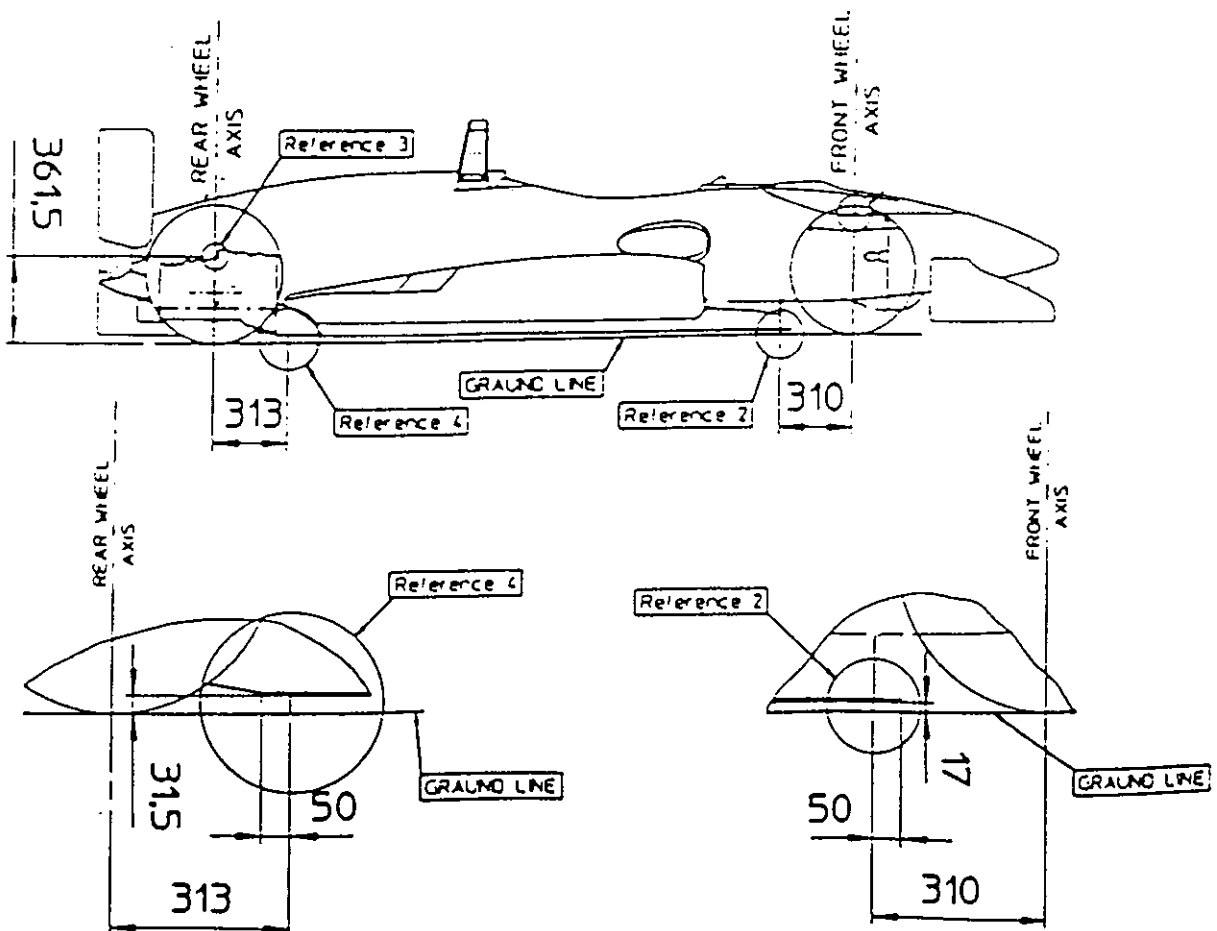

POWER FLOW DIFFERENTIAL

WORKING PRINCIPLE AND SETUP

This differential ("diffs") is designed with versatility as its major asset. Many parameters will lead you to the required setting. A car with good grip and low power may require a completely different arrangement than that for a high power/low grip car.

The working principles of powerflow differentials:

Ten friction plates within the diff, six connected to the side gears, four to the diff casing, control the amount of differential action available. The amount of limited slip depends only on the frictional resistance between these ten plates.

Four factors contribute in defining this frictional resistance (see figure next page):

1. The bevel gears thrust apart as soon as the car moves. This is a feature of bevel gears and is not adjustable;
2. The ramp angle on the side gear ring influences the amount of the driving force on the diff round that is directed sideways and onto the plates. E.g., on the power/drive side ramp, 45 degrees transmits less force sideways than 30 degrees. Likewise, on the brake/coast side ramp, an 80 degrees angle will transmit little or no force while 45 degrees does. Check to see which different side rear rings are available for each model of diff. 60°/80° is normally fitted as standard;
3. The pre-load with which they are assembled to start. In each diff there is a pre-load spacer that looks like one of the B plates, but thicker. Depending on diff model, it is either the first or last component assembled into the diff casing. Its thickness dictates to what degree the plates are pre-loaded / forced against each other. The pre-load is set and checked on each diff by holding one side gear still, via a dummy output shaft held in a vice, and by turning the other with a torque wrench. If the measured resistance is deemed too high, the spacer is ground down until the desired figure is achieved (usually between 5 to 20 lbs ft). The figure should be checked periodically as it tends to reduce as the diff runs, meanwhile a new A, slightly thicker spacer will allow re-setting;
4. The final and easiest adjustment is the re-arrangement of the contact order of the plates. The arrangement 1, with a plates succession A, B, A, B, A, has the maximum number of working friction faces and is the standard one. It gives the maximum resisting torque. The arrangement 3 has the minimum of working friction faces and gives the minimum resisting torque. By swapping from arrangement 1 to 3, the resisting torque approximately halves.

AVAILABLE RAMP ANGLES

Power side	Brake side
30°	60°
60°	80°
80°	80°
45°	80°
45°	45°

DIFFERENTIAL LAY-OUT

- Make sure the plate arrangement is always equal on left and right-hand side.
- Side gear ring, diff end plate, diff wall and pre-load spacer all act as "B" plates
- Bigger ramp angle transmits less thrust onto plates than smaller one.

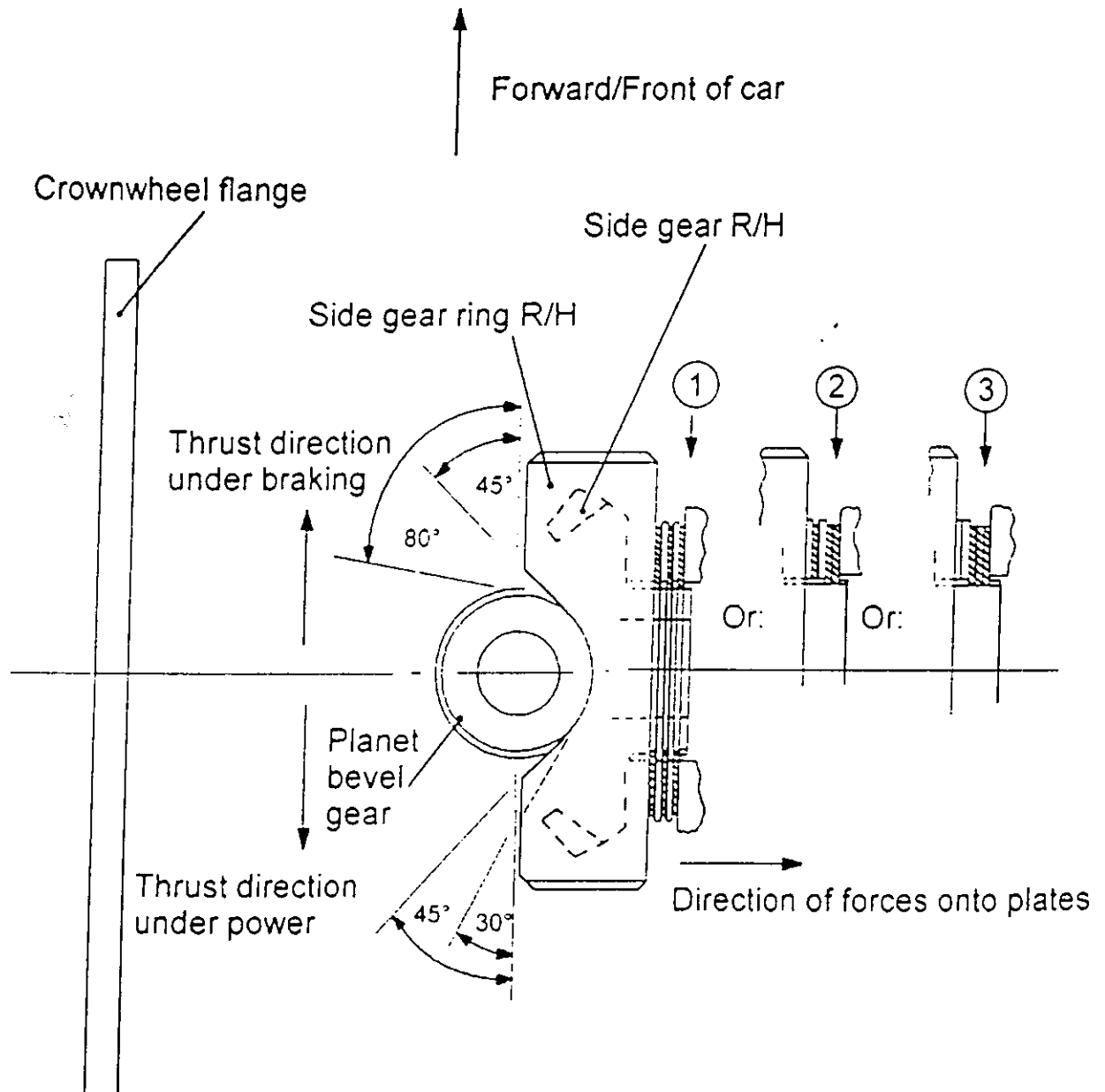

- | | | | |
|--|------------|---|--------------------------|
| | "A" plates | ① | 6 friction faces working |
| | "B" plates | ② | 4 friction faces working |
| | | ③ | 2 friction faces working |

DAMPERS

DIMENSIONS & GENERAL INFORMATION

- Standard dampers are KONI 2812-140. Front and rear dampers have identical valving, the same full-extended length and identical installation parts. Damper assembly dimensions are:

	mm
full open length	335
full closed length	
(front)	297
(rear)	291
stroke	
(front)	38
(rear)	44

- The difference in stroke and full closed length is due to the 6mm Teflon spacer on **front damper** to prevent the rocker to lock. If you use different dampers check that max stroke is not more than 38 mm.
- The standard Koni damper has about 30kg of pre-load, due to the internal gas pressure.
- Dallara, on request, delivers installation kits for PENSKE and QUANTUM dampers. Eibach dampers can be installed using standard mountings.

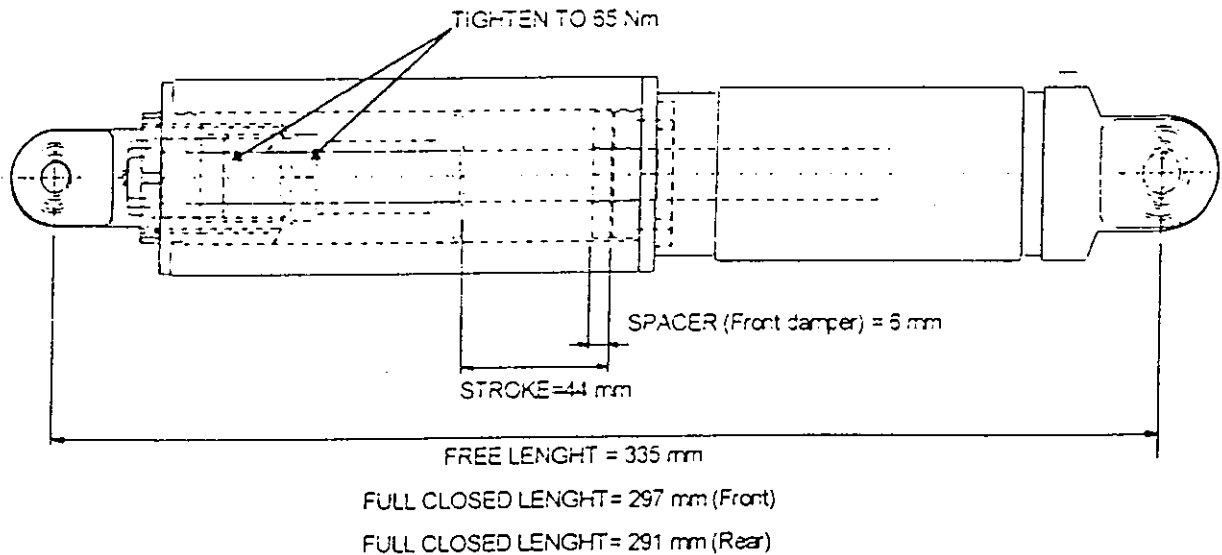

DAMPERS DIAGRAM

The Koni dampers are adjustable both in bump and rebound by acting on the adjuster wheels marked B (for bump adjustment) and R (for rebound adjustment) on the damper top. Each adjuster wheel has eight different positions.

KONI 2812/140

Figure shows force/velocity graphs for full soft and full stiff settings.

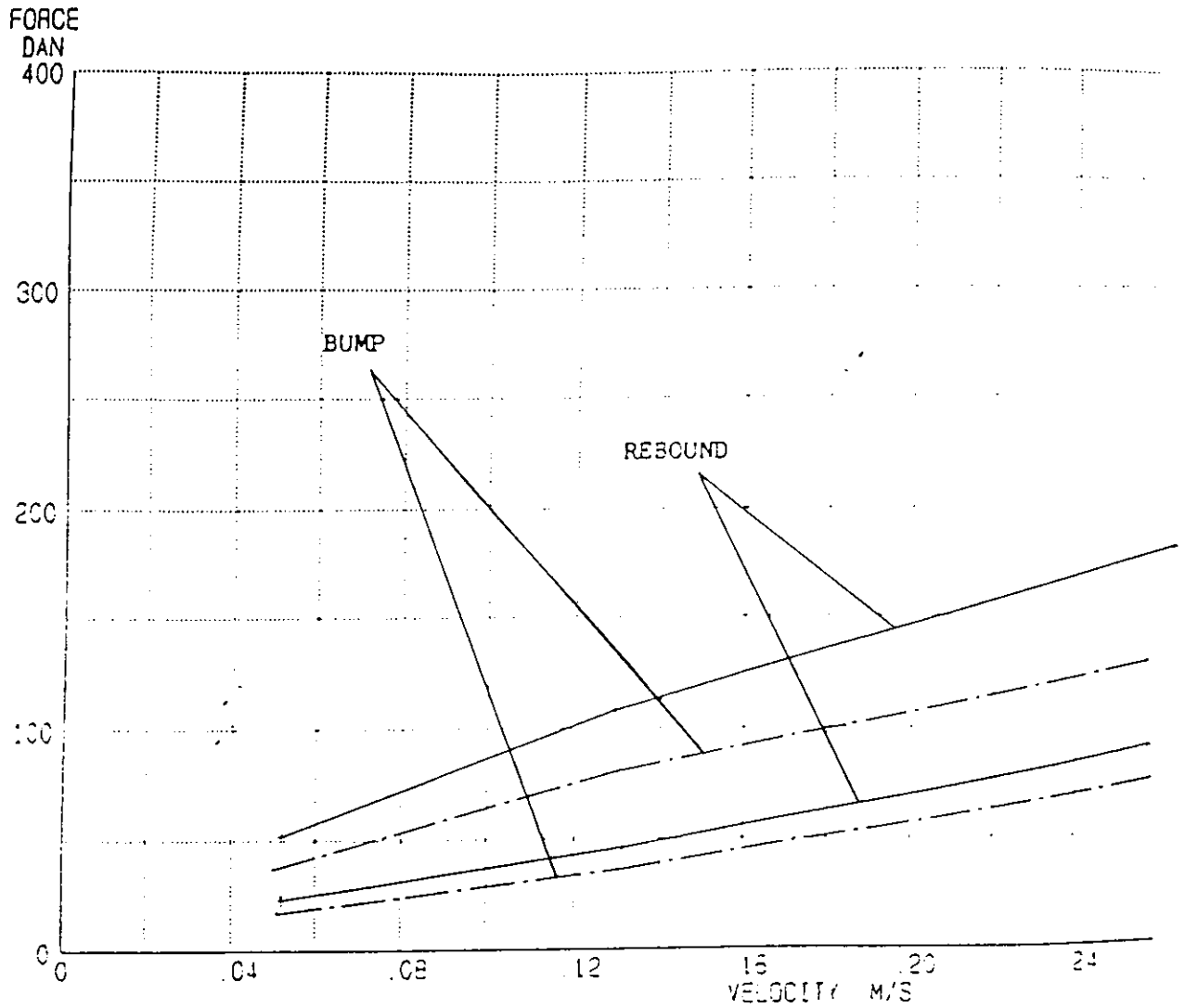

FRONT WING

FRONT WING CONFIGURATIONS

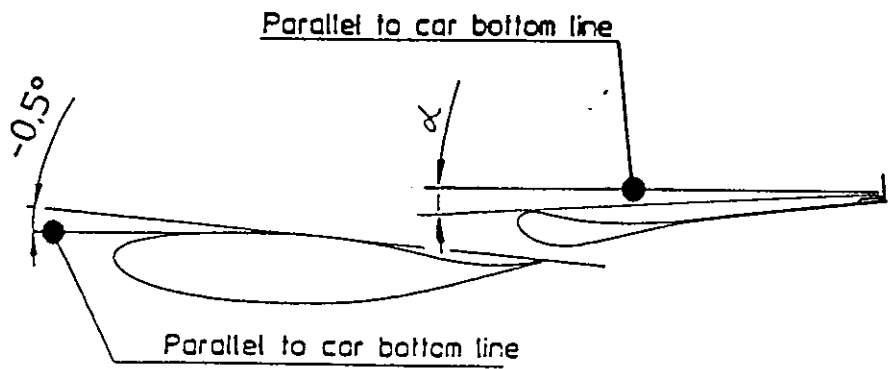
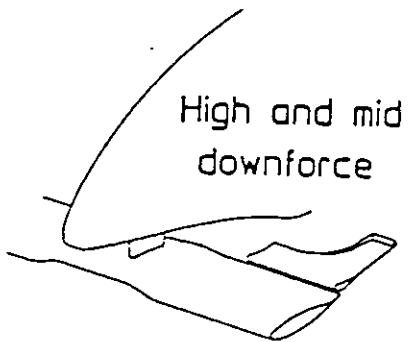
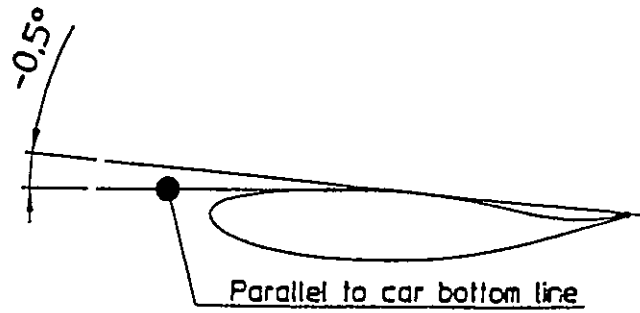
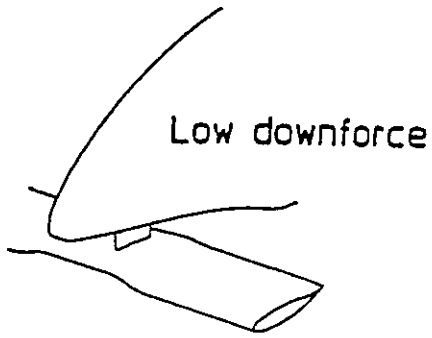

FRONT WING SIDEPLATE HOLES

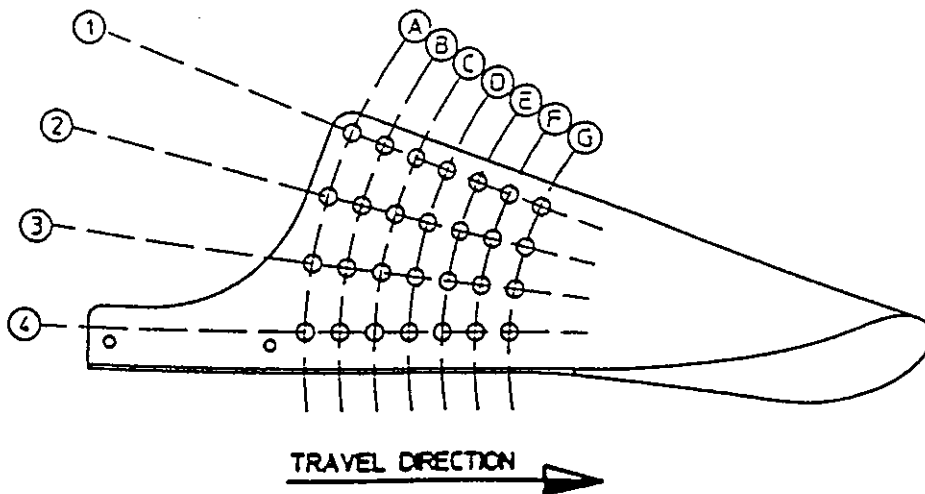

REAR WING

REAR WING PROFILES

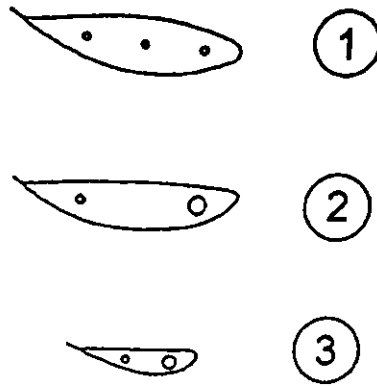

REAR WING CONFIGURATION

LDF
LOW DOWNFORCE

MDF
MID DOWNFORCE

HDF
HIGH DOWNFORCE

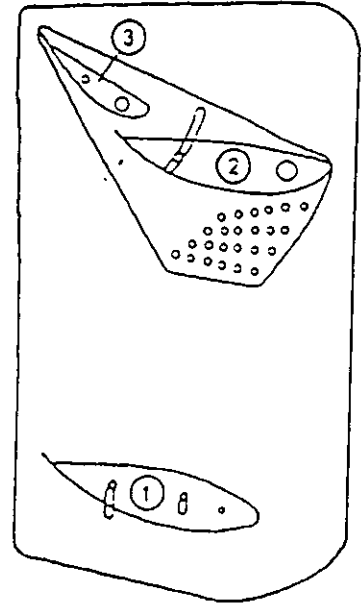
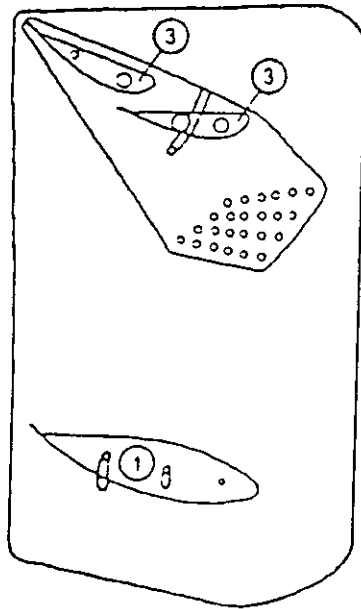
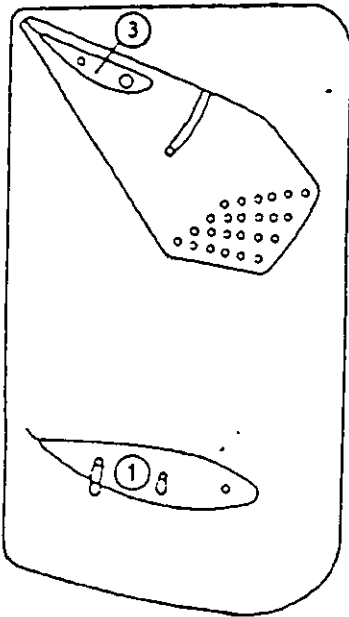

REAR WING SIDEPLATE HOLES

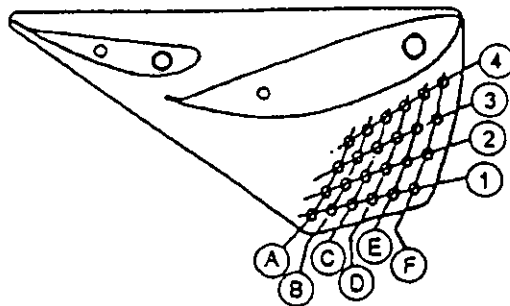

FRONT AND REAR WING SIDEPLATE TABLE

- Front flap angle is measured on top of the flap front and inside the Gurney 'corner', as shown on page 20.
- Correspondence between holes and incidence angle is just indicative, because wing angle is also function of front and rear ride heights.
- The machined side-plates allow 1 deg step adjustment.

FRONT FLAP

	A	B	C	D	E	F	G
1	8°	9°	10°	11°	12°	13°	14°
2	15°	16°	17°	18°	19°	20°	21°
3	22°	23°	24°	25°	26°	27°	28°
4	29°	30°	31°	32°	33°	34°	35°

REAR TOP

	A	B	C	D	E	F
1	0°	1°	2°	3°	4°	5°
2	6°	7°	8°	9°	10°	11°
3	12°	13°	14°	15°	16°	17°
4	18°	19°	20°	21°	22°	23°

POLAR DIAGRAM

Every point corresponds to a downforce level listed below.

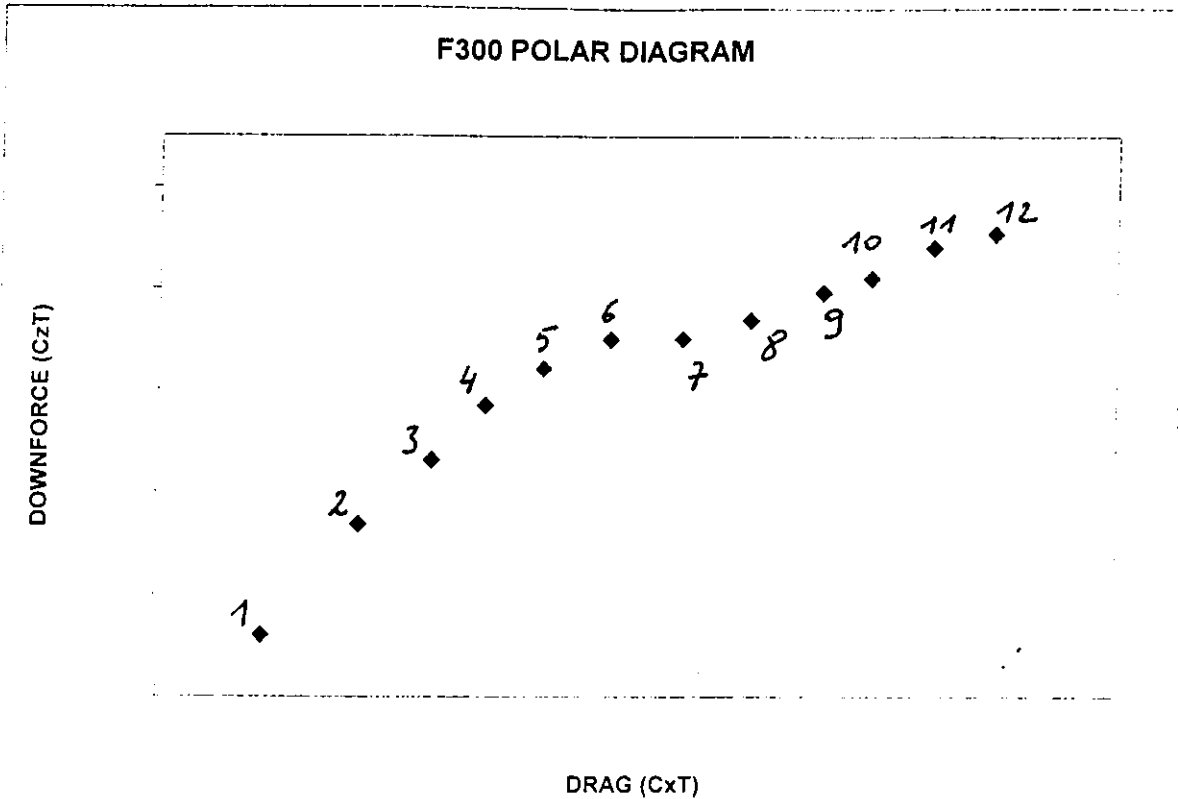

REAR

FRONT

LDF= Low Down Force (single small top)	MF= Medium Flap (small flap)
MDF= Medium DF (twin small top)	SF= Standard Flap
HDF= High DF (small and mid combined top)	EF= Extended Flap (standard plus extension)

CFG	REAR			FRONT			CFG
	TOP TYPE	SETTING	LOWER	FLAP TYPE	SETTING	MAIN PLANE	
1	NONE	-	1	NONE	-	-0.5	1
2	LDF	2	5	MF	9	-0.5	2
3	MDF	6	5	MF	14	-0.5	3
4	MDF	10	5	MF	18	-0.5	4
5	MDF	14	5	MF	22	-0.5	5
6	MDF	18	5	MF	26	-0.5	6
7	HDF	11	5	SF	16	-0.5	7
8	HDF	14	5	SF	18	-0.5	8
9	HDF	17	5	SF	20	-0.5	9
10	HDF	17	7	EF	20	-0.5	10
11	HDF	20	7	EF	22	-0.5	11
12	HDF	23	7	EF	24	-0.5	12

ALL NUMBERS ARE DEGREES

AERODYNAMIC information

- Front wing main-plane and rear lower wing, are set relative to the chassis reference plane.
- The optimum setting for most of the setting range is for front wing main-plane -0.5° , and for the rear lower wing $+5^\circ$. Any chassis rake angle will alter this setting.
- Front flap inclination is intended to be the angle, relative to the chassis reference plane, measured between front of the flap, on top and rearmost trailing edge (without any Gurney).
- Rear top wing assembly inclination is intended to be the angle, relative to the chassis reference plane, measured between front of the flap, on top and rearmost trailing edge. Any chassis rake angle will alter this setting.
- Front and rear ride height settings are fundamental to the aerodynamic balance and ultimate performance of the car. Pay attention to the changes between the static setting and the dynamic values on track.

Downforce CFG	Part	Min Suggested		Max Suggested	
		Hole	Incidence	Hole	Incidence
Front	Flap	A1	8°	C4	31°
Rear top LDF	Wing	C1	0°	B2	5°
Rear top MDF/HDF	Wing	A1	0°	A4 / F4	$18^\circ/23^\circ$

How to balance 1° FR flap variation by changing the rear wing, RR ride height or FR ride height?

RR TOP →	LDF		MDF		HDF		
FR - FR FLAP	MF	2 holes RR top	MF	1 hole RR top			
		1.5mm lower RR height		1.5mm lower RR height			
		1mm higher FR height		1mm higher FR height			
				SF	2 holes RR top	SF	1 hole RR top
					3.5mm lower RR height		2.5mm lower RR height
					2mm higher FR height		1.5mm higher FR height
						EF	2 holes RR top
							2.5mm lower RR height
							1.5mm higher FR height

MF: Medium Flap; **SF:** Standard Flap (as '99); **EF:** Extended Flap

COOLING ADJUSTMENT

Depending on air temperature and engine optimum water temperature you can set the cooling capacity of the radiators. Efficiency increases by sealing any eventual leakage in the inlet ducts to the radiators.

FRONT UPRIGHT

SAFETY NOTE

We advice to regularly check the **lower stud on the front uprights**, which could show little cracks difficult to detect by men's eye. Use penetrating liquid to check these studs after each accident and according the following schedule: **Check after 3000km, 4000km and 5000km, after 5000km each 500km or after each race meeting or test day.**

HUB ASSEMBLY

The following procedure tells to change front and rear hub bearings

- **Removal of bearing**
 - a) Remove spigot by removing the 6 screws A;
 - b) Push off drive flange by using two 6x1 screws set on thread B;
 - c) Remove seeger C;
 - d) Press off bearing from the upright;
 - e) Push off retainer by means of two 6x1 screws set on thread B.
- **Replacement of bearing**
 - a) Press wheel bearing into the upright;
 - b) Fit seeger C;
 - c) Press the retainer into the wheel bearing;
 - d) Place spigot in position on the drive flange, fit A screws, washers and nuts and tighten to 41 Nm (**Caution**: this value is for 12K screws only).
- **Wheel stud removal**
 - a) To reduce resistance to Loctite, heat wheel stud and retainer to 180°C;
 - b) Remove pin D, remove wheel stud.
- **Wheel stud replacement**
 - a) Remove pin D;
 - b) Clean and degrease retainer thread and wheel stud;
 - c) Spray degreaser to threaded area of retainer and wheel stud. **Caution**: Don't use petrol;
 - d) Apply LOCTITE 638™ to wheel stud thread;
 - e) Screw wheel stud into retainer and tighten to 245 Nm by forcing on head T;
 - f) Drill wheel stud and insert pin D.
- **Bearing assembly into hub replacement**
 - a) Warm the hub to 100°C;
 - b) Fit the bearing assembly

HUB ASSEMBLY

FRONT HUB

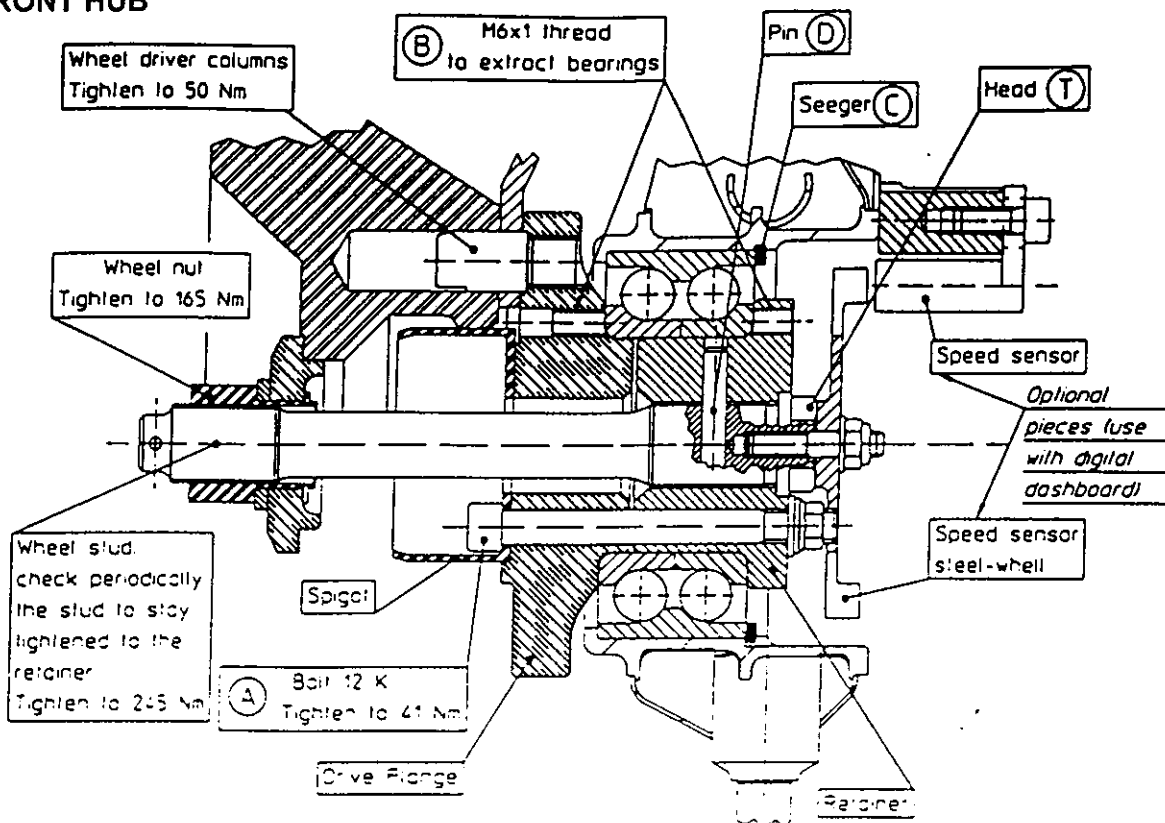

REAR HUB

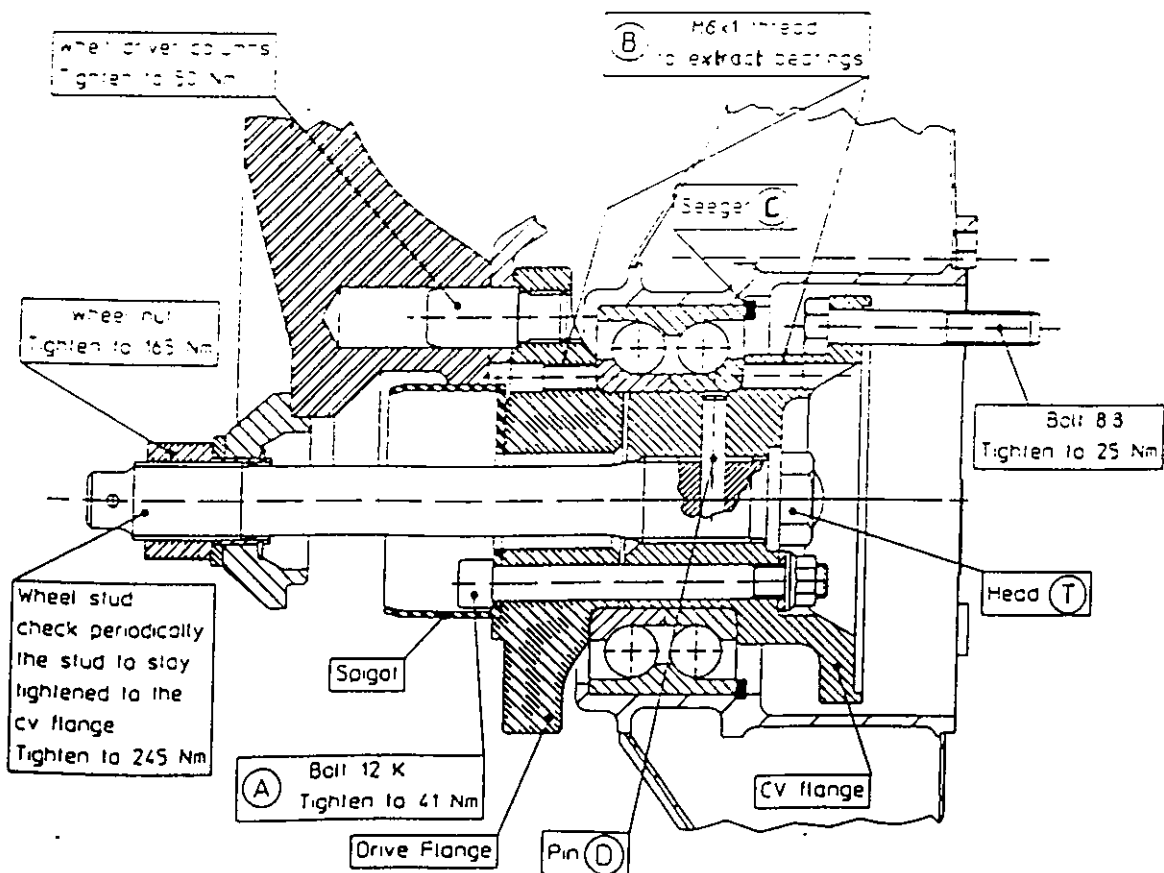

SYSTEMS

ENGINE OIL SYSTEM

We recommend keeping the oil level at 115 mm from the oil cap, measured with running engine.

Less oil may cause cavitation and so air to get into the oil circuit.

More oil may cause power loss.

Typically you would need 4.5 litres to fit in the oil tank, or 5.0 when using an oil cooler.

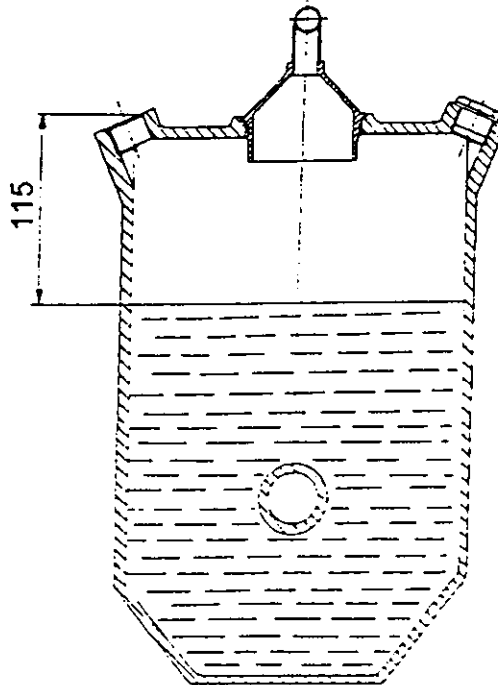

GEARBOX OIL

Typically you would need 1.2 litres to properly run the gearbox and the differential.

BRAKE SYSTEM

BREMBO BRAKE CALIPER ASSEMBLY

Travel direction 

Rear wheel

Front wheel

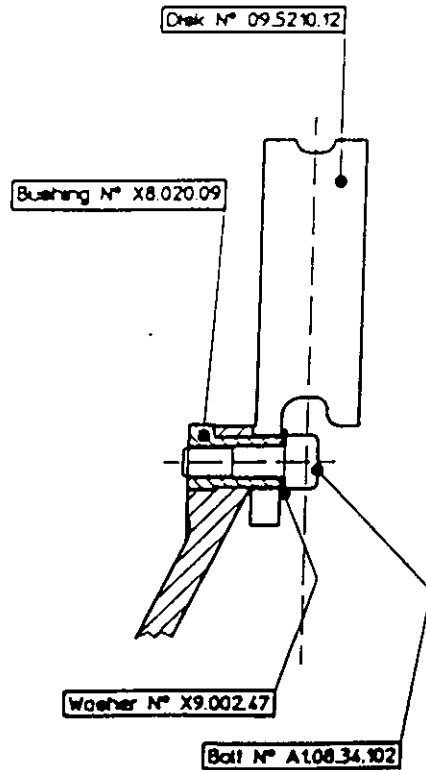
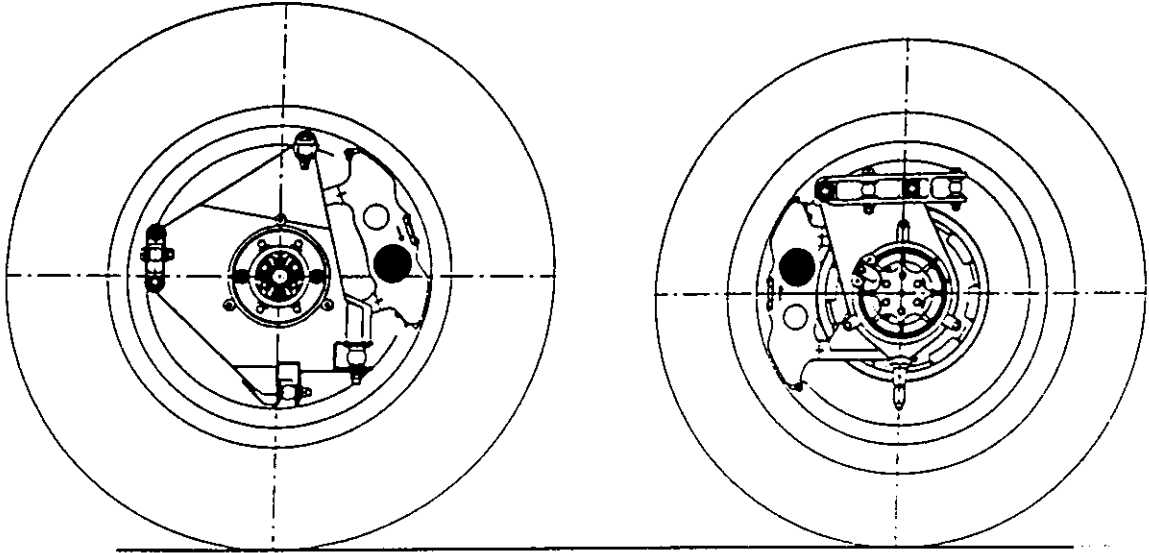

FUEL SYSTEM

- F300 features twin electrical-submerged fuel pumps as a redundant caution in case one pump fails. The driver can switch between the two pumps from the cockpit.
- OPEL-Spiess installation has a specific high-pressure pump.

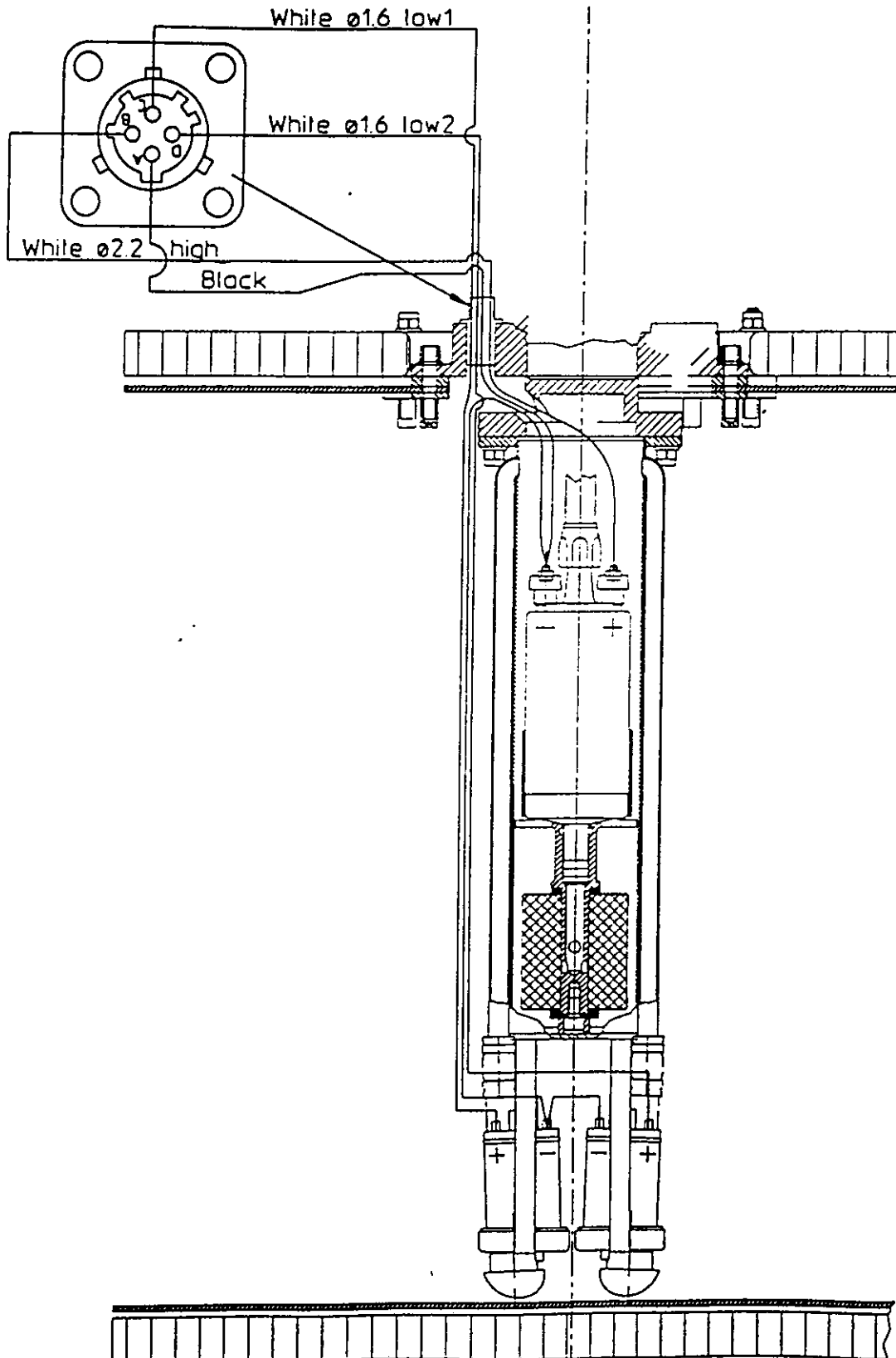

ELECTRICAL SYSTEM

Analogue dashboard wiring

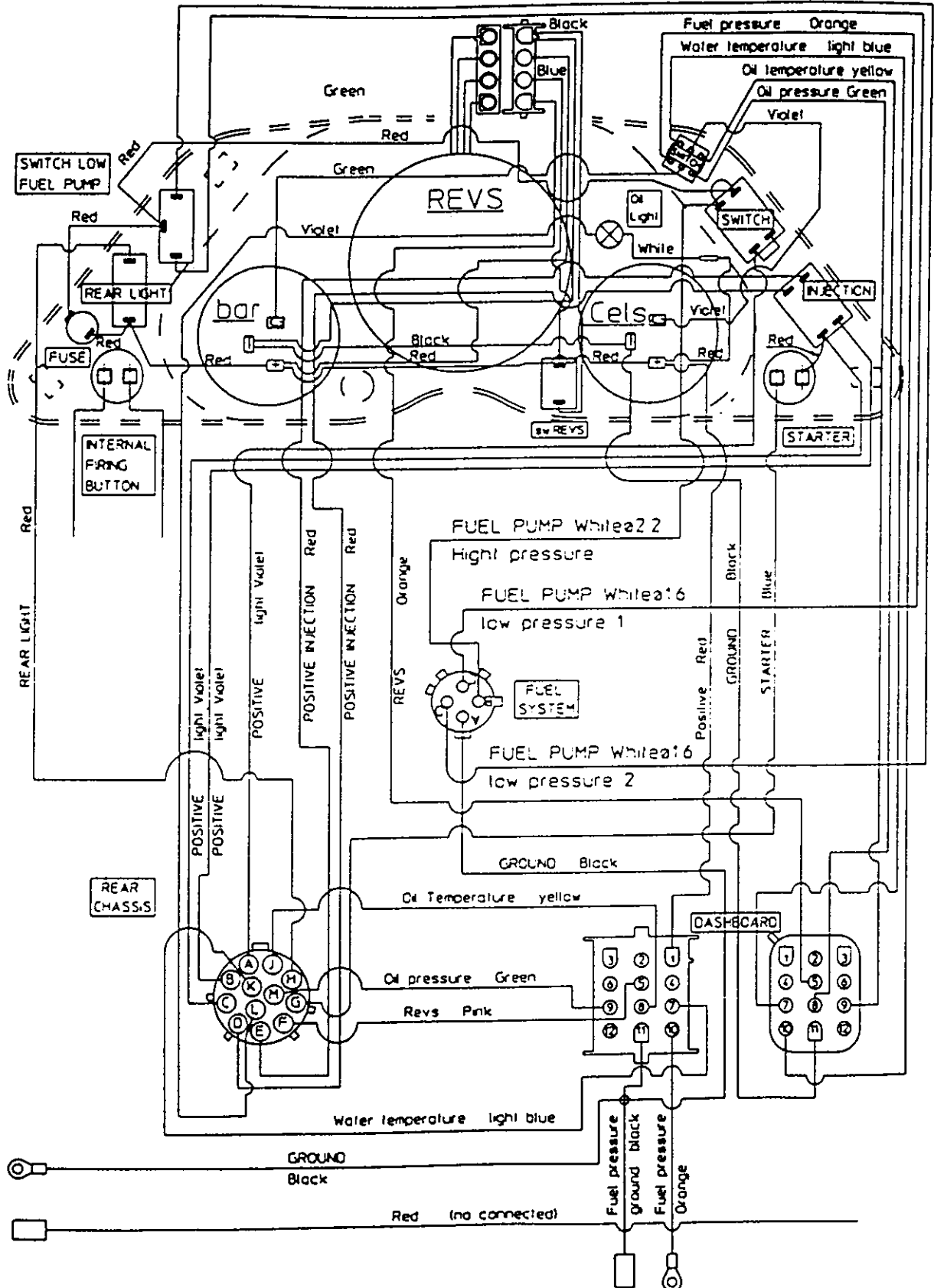

MARELLI dashboard wiring

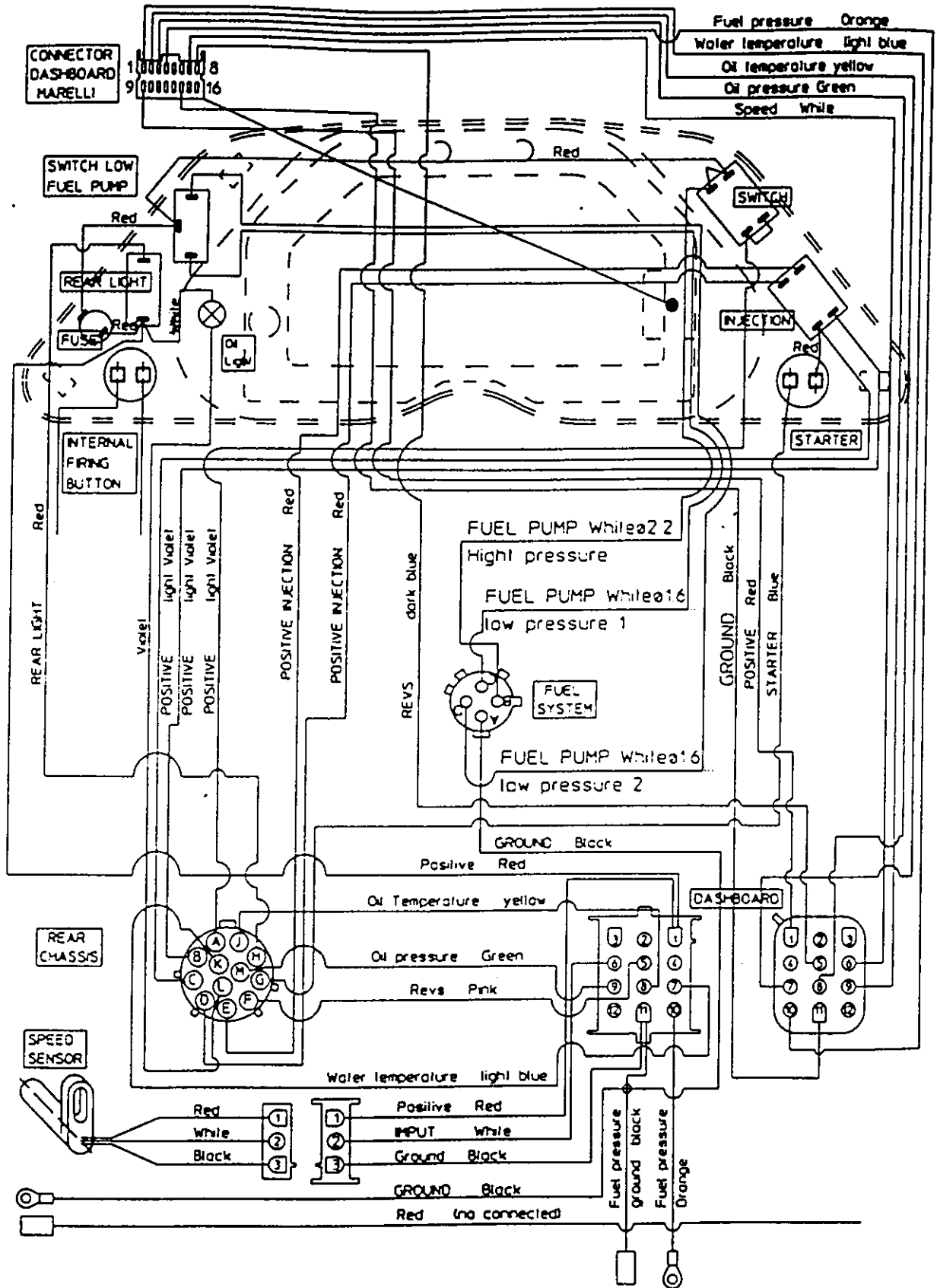

STANDARD ENGINE WIRING

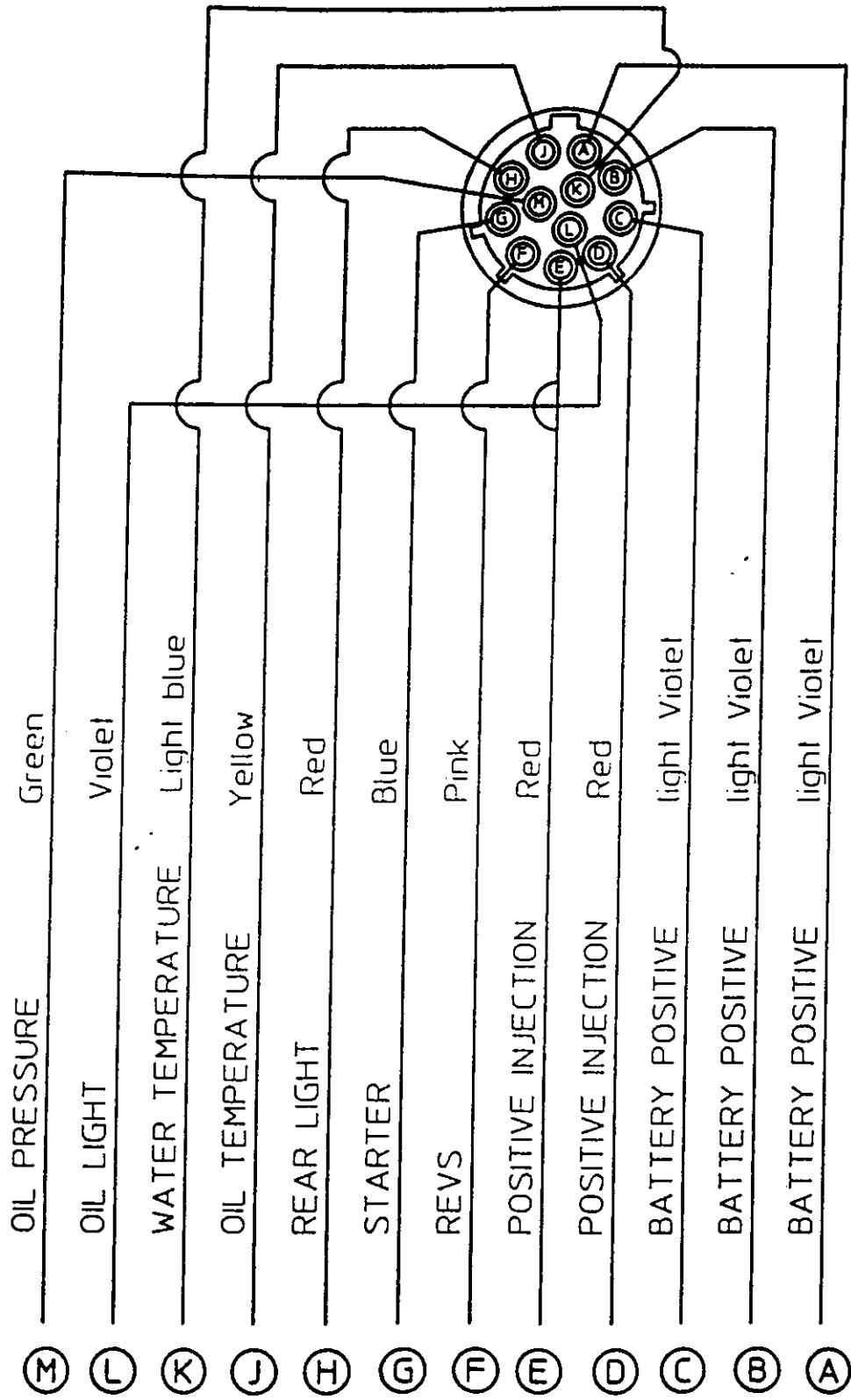

EXTINGUISHER SYSTEM LAYOUT

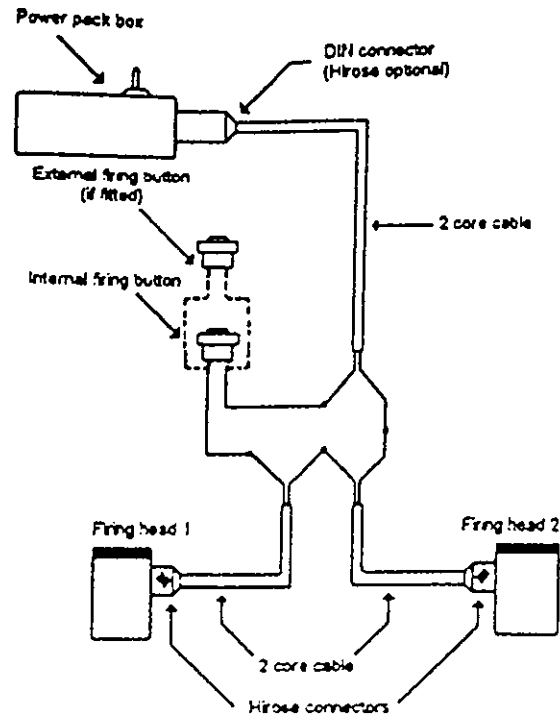

DETAILS

The SPA Fire Fighter system is an electrically triggered Halon or foam spray fire extinguisher system. The system uses actuators to operate the valves located on the pressurised container, containing the extinguishing liquid. These are triggered remotely using a battery powered 'power pack'.

In order to guarantee reliability the actuators are of military specifications. The system/battery test electronics are integrated into the remote power pack. Connectors on the firing heads are also of military grade and use two contacts per lead to guarantee the best connections.

Actuators are designed either to operate individually, or connected in series if two heads are used.

TESTING

The power pack electronics can test the continuity of the electrical wiring, and provides a high current pulse test on the battery, to ensure system integrity before use. The battery test electronics do not excessively drain the battery during this test.

The tests are carried out using a three-way switch on the power pack. Since the system is only as good as the battery that powers it and the integrity of the wiring and its connections, the tests should be performed before each race.

To check the battery, press and hold up the power pack switch. Every 2 seconds you'll see a YELLOW light flash. If the light flashes very dimly the battery should be replaced. In doubt change the battery.

To check the wiring continuity, ensure that the power pack switch is on "SYSTEM INACTIVE" to ensure that the extinguisher is not fired. Press the internal firing button and check that the RED light comes on. Press the external firing button and check that this also makes the RED light comes on.

CARES

Ensure that the electric 'command' cables are not laying next to or in the same loom as the car battery power cables or ignition cables. Ideally, all cables should lay next to the chassis (earth);

Ensure that all plugs exposed to water spray are protected with rubber boots;

If tubing is to be removed, push orange collet in. While holding in the collet, pull out the tube;

Avoid any cable to run over sharp edges without protection;

Do not fix the cables next to or onto any surface likely to exceed 200 °C;

Do not turn the firing heads when the system is activated.

GEARBOX

GEARBOX BEARINGS AND TORQUES

For ease of maintenance and replacement you find in this drawing the standard fitted bearings in the gearbox and the tightening torques we suggest for the primary and secondary shaft nuts.

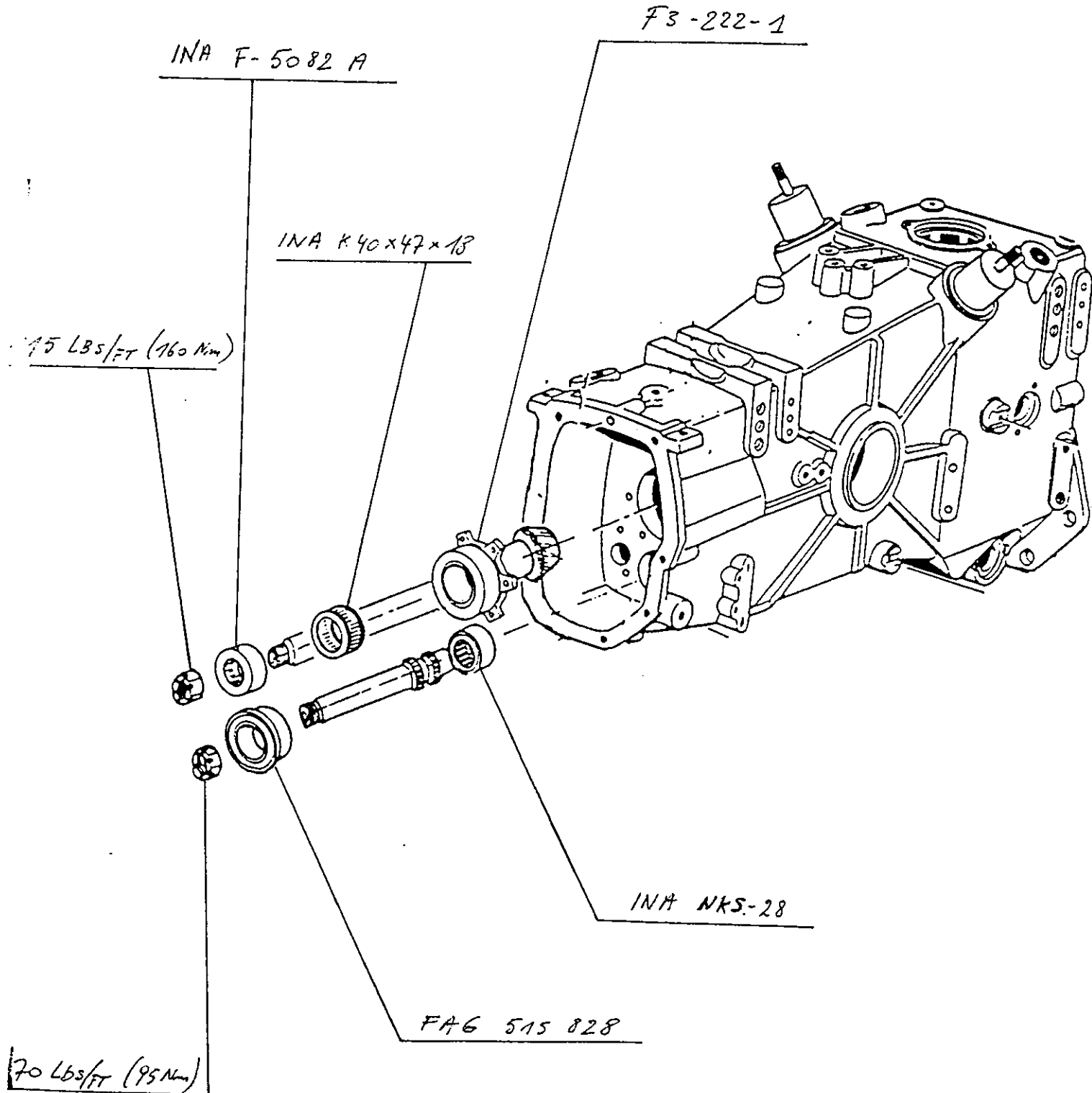

SAFETY AND UTILITY NOTICES

In case of anomalies, contact immediately Dallara.

SAFETY NOTICES

STUD INSTALLATION AND REMOVAL

It is very important to take an extreme care when removing and substituting the studs.

Typically use:

Loctite 270 (soft Loctite) for suspension brackets, brake calipers

Loctite 242 (hard Loctite) for chassis, gearbox, bell-housing, roll hop

Most of these studs are loctited and do require a proper installation procedure to follow

- Clean the hole from dust, debris
- Drive a screw tap to remove machining residuals
- Clean the hole with compressed air
- Pre assemble the stud without Loctite and remove
- Clean the hole again with a degreaser and dry with compressed air
- Coat the hole with Loctite
- Install the stud
- Tight the stud with the recommended tightening torque, you can do so by using a pair of nuts locked against each other.

TRANSMISSION:

To prevent the drive-shaft bolts from loosing, fit them with LOCTITE 242;

FIRE SYSTEM:

Take good care to the fire extinguisher: F399 models have electrically operated activation with small explosive charge. Notice to all the team crew for improper handling.

AERODYNAMICS:

It is forbidden to extract from mid downforce rear wing assembly the small profile and to use it for the rear low downforce configuration because they are differently reinforced. Buy the specific part.

When running the car with a rear ride height of 45mm or more, please, check the height of the wing endplate. Total height cannot exceed 900mm.

STEERING:

Steering rack side tie rod ends must be absolutely replaced in case of crash.

FUEL SYSTEM:

Dallara, on request, can deliver quick release adapter for the fuel line connector

CLUTCH:

When using a thicker than F3 typical AP twin-plate metal clutch (i.e. carbon clutch...), please check that the clutch piston can move backwards enough to release the clutch completely. You can shorten the clutch piston spacer by turning off the required amount.

WISHBONES:

Never lift up the car, taking the middle of the wishbones. Never sit or stand on the wishbones.

SUSPENSION

- Check pin to inner hub tightening both for front and rear upright assembly. You can notice if the locknut came loose by observing relative displacement of two red notches on locknut and on spigot.
- Check every 1000 Km lower pin locknut of front hub to prevent coming loose.
- Check the front upright lower stud on cracks after 3000km, 4000km and 5000km, after 5000km check them every 500km or after each race meeting or test day.
- After any accident, check alignment of front and rear pushrod and of their respective adjusters.
- Wishbones are treated with PARCO-LUBRITE. Clean the surface with acetone before inspection.
- Check periodically the K-nuts, which fixes the blades of rear antiroll bar to the drop links: they shouldn't come loose.
- Ball joint A, used in front lower and rear lower wishbones, must be fitted with sharp side in contact with seeger B, as shown in following sketch.

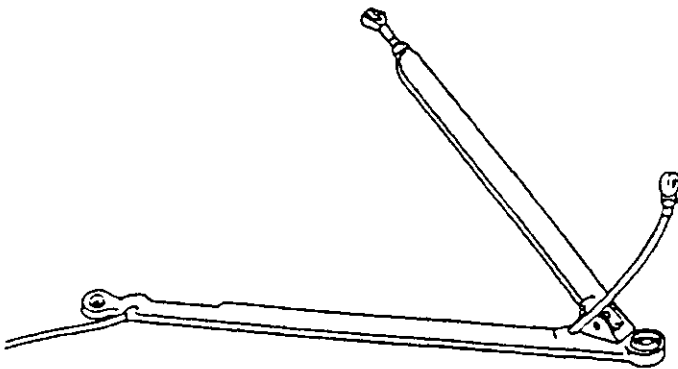

Front lower wishbone

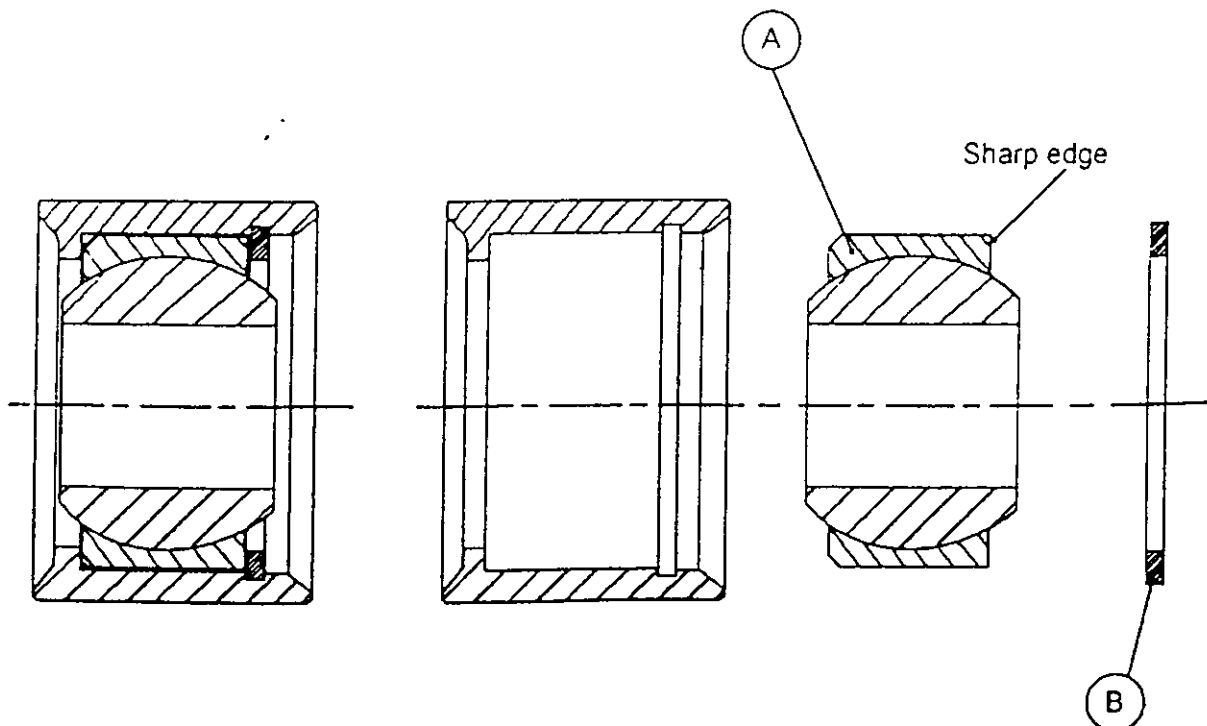

TIGHTENING TORQUES

The table lists some suggested tightening torques. For additional security use LOCTITE 242 or 243.

Tightening torques:	Nm	Kgm	lbs ft
Bevel gear nuts	330	33.5	250
Lay-shaft / main-shaft nuts	198	20.2	150
Final drive bolts	73	7.5	55
Brake disc bolt	7	0.7	5
Brake caliper studs	50	5.1	38
Wheel nut	165	17.0	125
Wheel stud	245	25.0	185
Damper end-stroke spacer	65	6.6	49
Wheel driver columns	50	5.1	38
Nut 7 × 1 (see hub assembly)	17	1.7	13
Bolt 8.8 (see hub assembly)	25	2.5	19
Bolt 12K (see hub assembly)	39	4	29
Rocker cap nut	34	3.5	25
Rocker stud nut	54	5.5	40
10-32 UNF 'K' nut	3	0.3	2
$\frac{1}{4}$ UNF 'K' nut	15	1.5	9
$\frac{5}{16}$ UNF 'K' nut	30	3.0	18
$\frac{3}{8}$ UNF 'K' nut	45	4.6	37

SWG & CONVERSION TABLE

This table provides conversion from SWG (Std Wire Gage) to metric units for sheet-metal thickness

SWG	8	10	12	14	16	18	20
Metric [mm]	4.064	3.251	2.642	2.032	1.626	1.219	0.914

CONVERSION TABLE**Length**

1 inch=25.4 mm	1 millimeter=0.03937 in
1 foot=304.8 mm=12 in	1 centimeter=0.3937 in
1 yard=914.4 mm=3 ft	1 meter=39.37 in
1 mile=5280 ft=1.60934 km	1 kilometer=0.62137 miles

Volume

1 cubic inch (c.i.)=16.387 cubic centimetres	1 cubic centimeter=0.061 cubic inch
	1 liter=1000 cc=61.0255 cubic inch

Pressure

1 psi=0.0716 bar	1 kg/cm ² =1.019 bar
	1 bar=10 ⁵ Pa=0.1MPa
	1 bar=13.95 psi

Weight

1 ounce (oz)=28.35 grams	1 Kg=1000 grams = 2.205 lb
1 pound (lb.)=16 ounces=453.592 grams	

Speed

1 MPH=1.467 feet per second	
1 mph=0.62137 kilometres per hour	1 kilometre per hour=1.60934 mph
1 IPS (in/s)=25.4 mm/s	1 mm/s=0.039 IPS

Specific weight

Water=1 kg/l
Mineral Oil=0.903 Kg/l
Gasoline=0.74 Kg/l

Useful formulas

Engine displacement=0.7854 × bore × bore × stroke × no. of cylinders
British horsepower (BHP)= RPM × torque (lbs ft)/5250
MPH=RPM × tire diameter (in)/(gear ratio × 336)
Km/h = RPM × tire diameter (mm)/(gear ratio × 5308)
Lap speed (MPH) =track length (miles) ×3600/lap time (seconds)
Lap speed (km/h) = track length (Km) × 3600/lap time (s)
Average speed (MPH) =track length (miles) ×3600 × no. of laps/total time (seconds)
Average speed (km/h) =track length (Km) ×3600 × no. of laps/total time (seconds)

GENERAL AGREEMENT AND WARRANTY

Motor racing is not covered by warranty due to the intentional choice of drivers to race in a dangerous environment

DALLARA indicates that under normal operating conditions a new car would not show failure in structural components before it has completed around 25000 Km. This holds true if necessary maintenance and checks are provided and if the car had no previous incidents. DALLARA is not responsible for incorrect chassis repairs, if made outside its factory or in centres not recognised by FIA.

Chassis should be checked for structural failure not later than two years after delivery from DALLARA factory, and after each major accident. After first check or after any major accident it is mandatory to check the chassis every year in a centre recognised by FIA authority.

DALLARA is not responsible for damage caused by non-genuine spare parts.

Under maintenance, following parts should be replaced after 25000 Km or two-years use:

- wiring loom;
- starter motor;
- steering column
- steering rack and tie-rods
- brake pedal;
- brake disc bell;
- wheel bearings;
- suspension arms and spherical joints;
- engine installation parts;
- drive-shafts;
- wings and rear wing supporting plates;

We firmly remind you that **Main roll over hoop**, **Monocoque** and **Front nose-box (crushable structure)** are **FIA approved** and cannot be modified by unauthorised personnel for whatever reason.

Any change to these parts is sufficient reason for disqualification.

FUEL SYSTEM LAYOUT

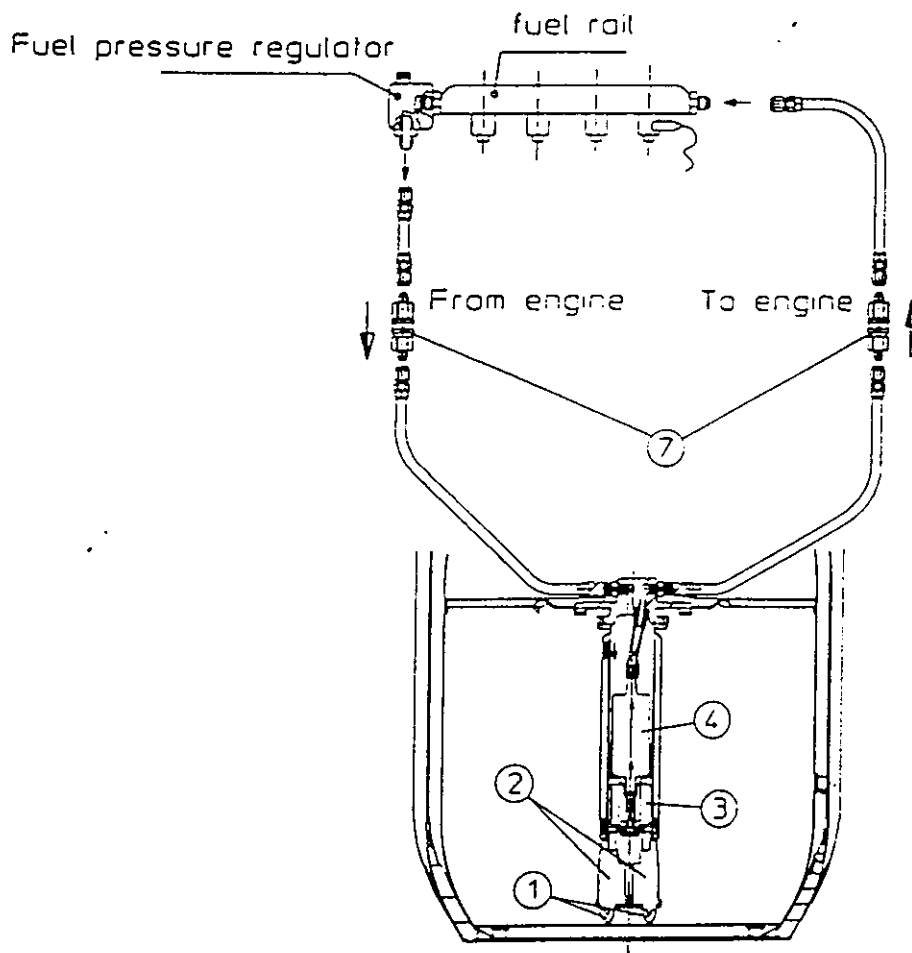
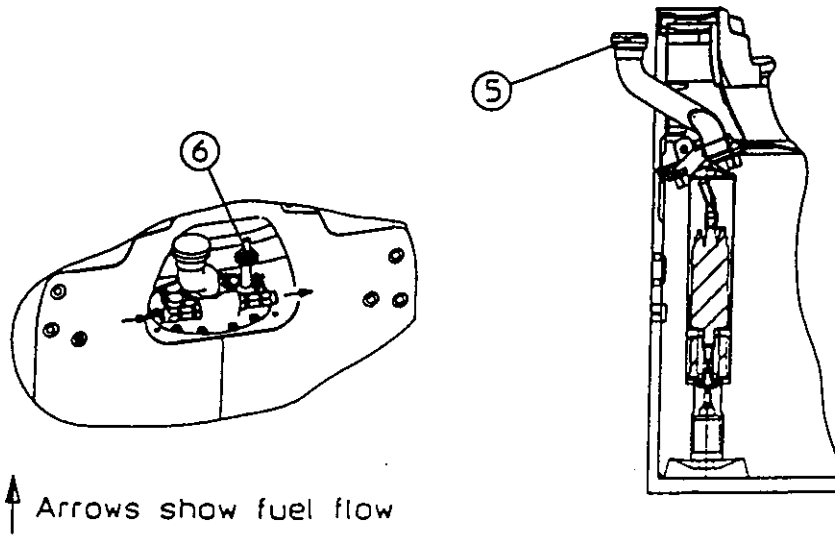

- 1) Filter
- 2) LOW pressure pump
- 3) Filter
- 4) HIGH pressure pump

- 5) Fuel cap
- 6) Breather cap
- 7) Quick release valve
also for fuel check



F3 STRUCTURE TESTING RECORD

Constructor : DALLARA Chassis type : F399
 Date : 31/08/1999 Place : Dallara factory
 Present : G. P. Dallara, J. Claes, K. H. Stegner, J. Bauer

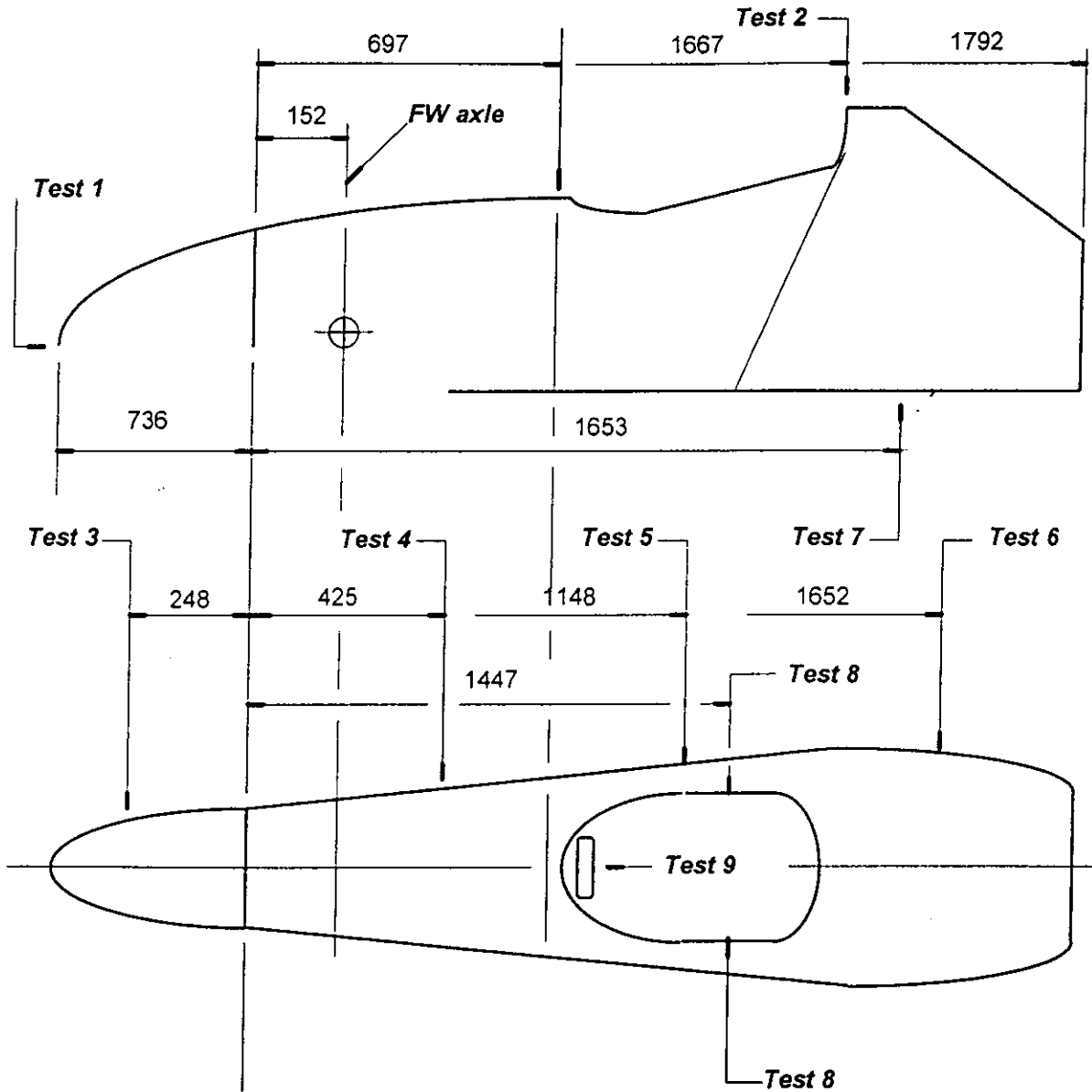

Test 2 : A 51.75kN load applied at a compound angle to the top of the main roll structure

Load 51.95 kN	Displacement 5.60 mm	100%	G = 560 kg
Load 58.00 kN	Displacement 6.40 mm	110%	G = 616 kg
Load 62.10 kN	Displacement 7.15 mm	120%	G = 672 kg
Load 67.30 kN	Displacement 8.90 mm	130%	G = 728 kg

Comments : Test carried out with reference weight of G = 560 kg as well as with the reference weight increased by 10%, 20% and 30%;
 OK. no visible damage 100 mm below the top of the rollover structure

Chassis number : F399 - 001

Test 2 : A 51.75kN load applied at a compound angle to the top of the main roll structure

Load 52.73 kN Displacement 8.90 mm

Comments : Test carried out with reference weight of 570 kg instead of 560 kg, ok. no visible damage

Test 3 : A 20.00kN load applied to the the nose side 40cm in front of the front axle line and held for 30 secs

Load 20.02 kN

Comments : OK., no visible damage

Test 4 : A 20.00kN load applied in 3 mins to the footwell side and held for 30 secs

Load 20.08 kN Displacement 0.55 mm (0.43 mm) Difference 100 % Deformation 0 mm

Comments : OK., no visible damage

Test 5 : A 20.00kN load applied in 3 mins in the seat belt area and held for 30 secs

Load 20.07 kN Displacement 4.37 mm 16 kN:3.54 mm Deformation 0.06 mm

Comments : OK., no visible damage

Test 6 : A 20.00kN load applied in 3 mins to the fuel tank side and held for 30 secs

Load 20.02 kN Displacement 1.00 mm (0.79 mm) Difference 100 % Deformation 0.05 mm

Comments : OK., no visible damage

Test 7 : A 10.00kN load applied in 3 mins to the fuel tank floor and held for 30 secs

Load 10.02 kN Displacement 3.80 mm (3.10 mm) Difference 100 % Deformation 0 mm

Comments : OK., no visible damage

Test 8 : A 10.00kN load applied in 3 mins to the cockpit rims and held for 30 secs

Load 10.07 kN Displacement 0.64 mm (0.50 mm) Difference 100 % Deformation 0 mm

Comments : OK., no visible damage

Test 9 : An impact test on the steering assembly at 7 metres/sec with a total mass of 8kg

1. Impact speed : 7.15 m/s Deformation : 33 mm

2. Impact speed : 7.11 m/s Deformation : 35 mm

1. Deceleration : Peak : 147.3 g Time greater 80 g : 1.1 ms

2. Deceleration : Peak : 277.9 g Time greater 80 g : 1.65 ms

Structure fixings : 2 x M6 bolts on bearing, on rack

Component weights: front part of the steering column: 665 g, collapsable part: 6 g, steering wheel: 680 g

Comments : test 1 carried out with centre pad on steering wheel, test 2 carried out without pad on steering wheel, quick release mechanism still working after both tests, both tests OK.



F3 STRUCTURE TESTING RECORD

Constructor : DALLARA Chassis type : F399 Chassis number : F399-001
 Date : 19/10/98, 16/12/99 Place : Politecnico Milan, Dallara factory, CSI
 Present : Prof. Caprile, M. Anghileri, H. Gutman, A. Toso, J. Bauer

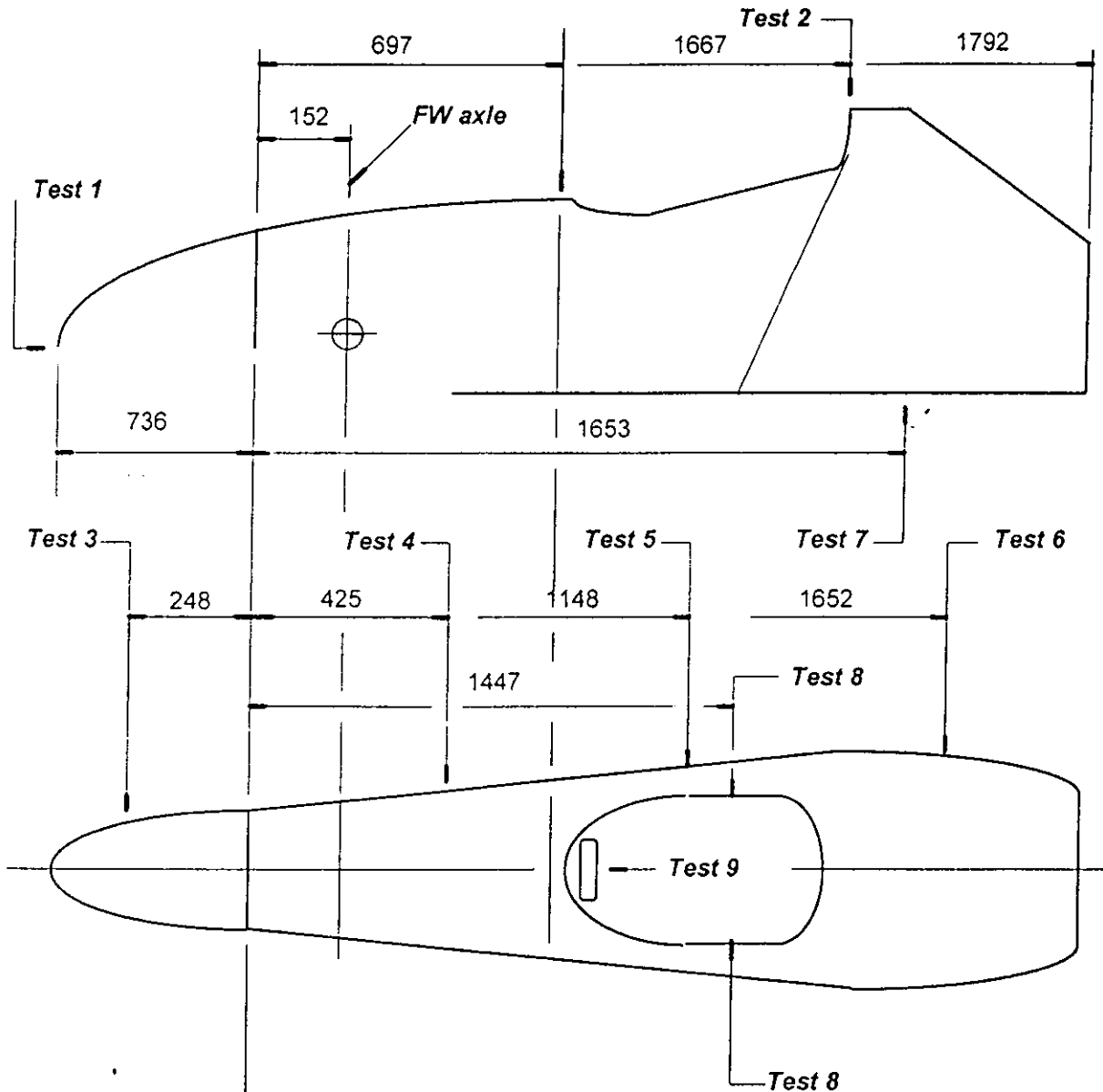

Test 1 : An impact test against a solid barrier at 10 metres/sec with a total mass of 560kg

Impact speed	: 1st 10.1 m/s	Deformation	: 1st 366 mm
	: 2nd 10.07 m/s		: 2nd 426 mm
Deceleration	: Peak : 1st 20.96 g	Mean	: 14.15 g
	: 2nd 19.25 g		: 12.17 g
Nose fixings	: 4 bolts, 8 mm diameter	Nose weight	: 1st 4.1 kg
			: 2nd 3.03 kg
Chassis weight	: 39.77 kg	First chassis	: 39.77 kg
		Difference	: 100 %

Chassis condition: bare unpainted chassis include. roll hoop, front damper bracket, seat belt fixations, brake balance cable & adjuster, fire extinguisher brackets, front anti roll bar studs

Comments : OK.



F3 STRUCTURE TESTING RECORD

Constructor : DALLARA Chassis type : F399 LWB
Date : 15/07/1999 Place : Dallara factory
Present : G Dallara, J. Bauer

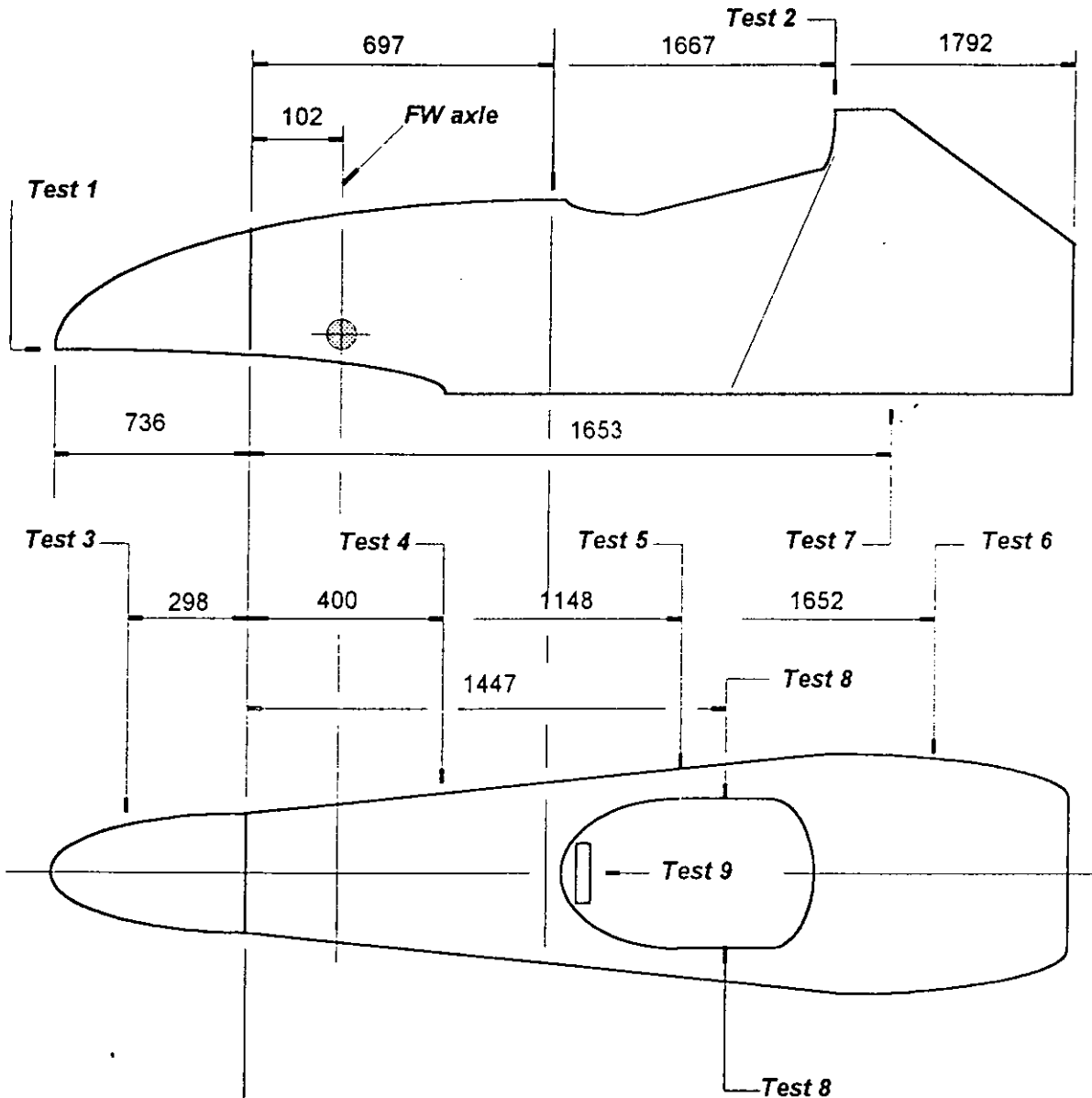

Test 3 : A 20.00kN load applied to the the nose side 40cm in front of the front axle line and held for 30 secs

Load 20.02 kN

Comments : OK., no visible damage on nose and fixation

Test 4 : A 20.00kN load applied in 3 mins to the footwell side and held for 30 secs

Load 20.00 kN Displacement 0.63 mm (mm) Difference 100 % Deformation 0.05 mm

Comments : OK., no visible damage

